

# PICO TABLE® / with Floating Mechanism

PPTF Series (with Buffer Mechanism)

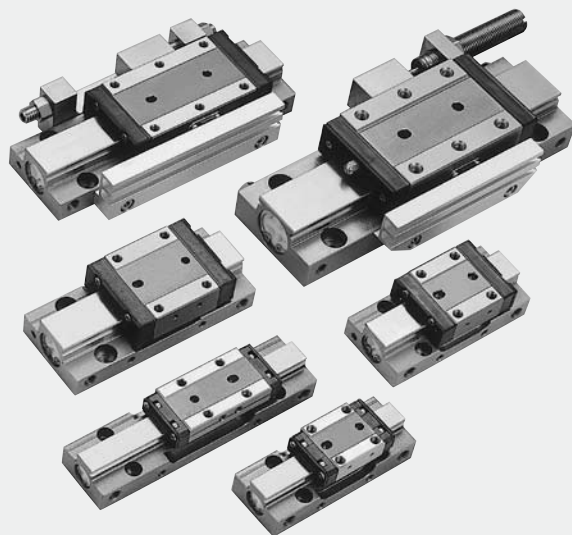

## INDEX★

Explanation, Example of Use, Installation Method	124
Operating Principle	125
Model Code No.	126
Specifications, Specification at Floating Part, Floating Direction	127
Spare Parts Code	128, 129
Product Mass, Theoretical Thrust	130
Guide to be used, Stroke Adjustment, Option Combination	131
Structure and Principal Components	132, 133
Modification of Port Position, Note for Safe Use	134
Spring	135
Dimensions	136~163

# Summary of the PICO TABLE with Floating(PPTF)Series

"PICO TABLE"(PPT series) could achieve extraordinary small, high accuracy and rigidity which linear bearing guide has in kind. That is the reason why PICO TABLE is made by combination with air cylinder and precision linear bearing. PPT with floating released in 1998.

PPTF is as same dimension as PPT. Because the floating mechanism can be built into the body of PPT. It is also possible to exchange the spring for floating.

There are four kinds of bore size. And there are three kinds of stroke adjustment, metal stopper, rubber stopper and shock absorber.

Besides, installation of switch that can detect position of stroke is available. The symmetric type is also available.

Refer to PPTG(with end lock and floating) P.207, PPTNF(clean type with floating) P.283.

## Application Examples : PICO TABLE with Floating

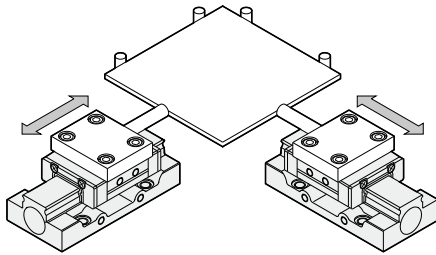

Movement of Clamping Pin

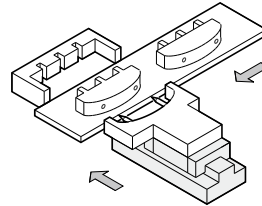

Feeding for Products

With Floating

PICO TABLE

PICO TABLE

### MAIN BODY INSTALLATION

(Bolt as shown in the figure are not supplied with products)

Top Mounting  
(Thru Hole used)

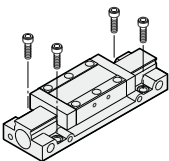

Bottom Mounting  
(Body Tap)

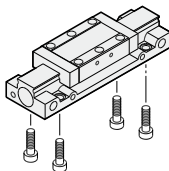

### MOUNTING

(Bolt as shown in the figure are not supplied with products)

Top Mounting

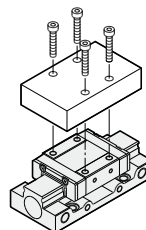

Side Mounting

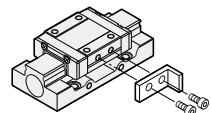

## MECHANICS FOR FLOATING

### ■Left cylinder room is pressurized

In this case, guide table is moved to the right end stroke by pressurized air.

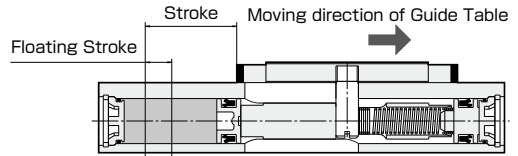

### ■At set; Right cylinder room is pressurized

When the right cylinder room in PPTF is pressurized, guide table moves to left. At the left side end stroke, the position of guide table is hold by a spring, not pressurized air.

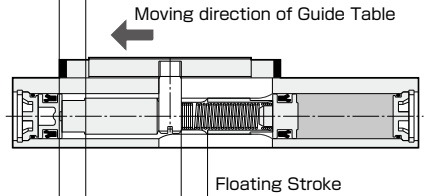

### ■At floating; Floating effect

The right cylinder room is pressurized, but the guide table nevertheless can move to right for floating stroke according to external force.

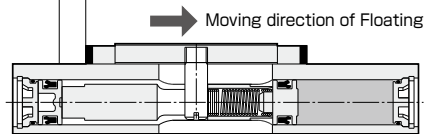

### ■Both cylinder rooms are exhausted

In this case, the guide table might be around the left side by a spring. This mechanism for floating is different from one for spring return. Thus position of the guide table might not be the left end stroke.  
(Note for Safe Use  P.134)

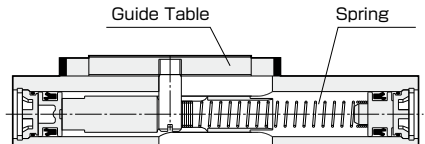

Model Code Example

# PPTFS-SR10-10-TPQR-RB12LA

Series Name ●

With Floating ●

Magnet and Switch Rail ●

No Code	None
---------	------

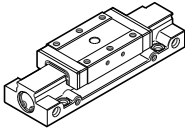

S	Magnet and Switch Rail
---	------------------------

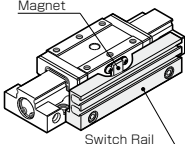

A magnet and switch rail is required when mounting switches.

● Bore Size

8	φ 8
10	φ 10
12	φ 12
16	φ 16

Stroke ●

Unit:mm

Model	Standard Stroke				
	10	15	20	25	30
PPTF8	●	-	●	-	-
PPTF10	●	-	●	-	-
PPTF12	-	●	-	●	-
PPTF16	-	-	●	-	●

● Cable Length

No Code	1m
LA	3m

● Number of Switches

1	1
2	2

Switch ●

No Code	None		
RB1	Straight	DC12~24V 2 Wires Reed Switch	With Indicator Light
RC1	Angle	DC12~24V 2 Wires Reed Switch	Without Indicator Light
RB2	Straight	DC12~24V 2 Wires Solid State Switch	With Indicator Light
RC2	Angle	DC12~24V 2 Wires Solid State Switch	With Indicator Light
RB4	Straight	DC5~24V 3 Wires Solid State Switch	With Indicator Light
RC4	Angle	DC5~24V 3 Wires Solid State Switch	With Indicator Light
RB5	Straight	DC5~24V 3 Wires Solid State Switch	With Indicator Light
RC5	Angle	DC5~24V 3 Wires Solid State Switch	With Indicator Light

Direction of Cable Outlet For details ☞ Page 1066, 1067

RB...

Straight Outlet Cable

RC...

Angle Outlet Cable

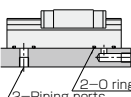

● Piping

TP	Side Ported
 <p>Install the air fittings to the ports directly.</p> <p>2-Piping ports</p>	
PP	Base Mounted
 <p>Attachment: Two O-ring By arranging the base, the air fittings can be mounted anywhere on it.</p> <p>The surface roughness of the base for O-ring should be 1.6umRa(6.3umRy) at the maximum.</p> <p>2-O rings</p> <p>2-Piping ports</p> <p>NOT available to shift the port position each other.</p>	

Direction of Floating ●

SR	To Right
SL	To Left
GR	To Right
GL	To Left

For details ☞ Page 127  
PPTF16 is possible to convert into following by changing blank plugs position.

SR → GL

SL → GR

Please note, it can not be converted into following.

XSR → GR

XSL → GL

For details ☞ Page 134

For the Option Combination ☞ Page 131



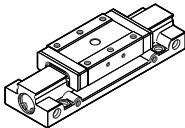
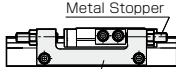
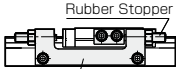
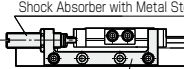

Stroke Adjustment Mechanism ●

No Code	Without Stroke Adjustment	QR	Both Sides Stroke Adjustment, Metal Stopper	QT	Both Sides Stroke Adjustment, Rubber Stopper	QK	Single Side Stroke Adjustment, Shock Absorber
			 <p>Metal Stopper</p> <p>For PPTF16, a split type is used.</p>		 <p>Rubber Stopper</p> <p>For PPTF16, a split type is used.</p>		 <p>Shock Absorber with Metal Stopper</p> <p>For PPTF8 and PPTF16, a split type is used.</p>

For details of stroke adjustment range ☞ See page 131

## SPECIFICATIONS

Model		PPTF8	PPTF10	PPTF12	PPTF16
Bore Size		φ8mm	φ10mm	φ12mm	φ16mm
Maximum Load Mass	Without Stroke Adjustment With Rubber Stopper With Shock Absorber	0.3kg	0.8kg	1.2kg	2.0kg
	With Metal Stopper	0.25kg	0.4kg	0.6kg	1.0kg
Port Size(TP Type)		M5×0.8			
Guide Mechanism		Precision Linear Ball Bearing			
Type of Operation		Double Acting			
Fluid		Air			
Maximum Operating Pressure		0.7 MPa			
Minimum Operating Pressure		0.15MPa			
	With Shock Absorber	0.25MPa	0.20MPa	0.15MPa	0.15MPa
Proof Pressure		1.05MPa			
Operating Temperature		5~60℃			
Minimum Operating Speed		50mm/s	30mm/s		
Maximum Operating Speed		120c.p.m.			
	With Shock Absorber	45c.p.m.		60c.p.m.	
Lubrication		Not Required			
Cushioning	Basic	None			
	Option	Rubber Stopper, Shock Absorber with Metal Stopper			

- Main Body and Load Bolt Mounting  Page 49
- Accuracy  Page 55
- Note for Safe Use  Page 56, 57
- Theoretical Deflection of Guide Table by Moment  Page 58, 59
- Allowable Load and Moment  Page 60~65

## SPECIFICATIONS OF FLOATING

Unit:N

Model	Stroke (mm)	Theoretical Force of Spring		Stroke of Floating (mm)
		At Set	At Floating	
PPTF8	10	3.2	4.0	3
	20	3.2	3.9	5
PPTF10	10	3.8	4.6	3
	20	3.8	4.5	5
PPTF12	15	4.4	5.5	
	25	4.4	5.1	
PPTF16	20	6.9	8.2	
	30	6.9	7.9	

Note: 'At set' is force of spring at the moment when floating stroke starts while pressurized. 1N=0.102kgf  
'At floating' is force of spring when floating moves to the stroke end while pressurized.

## DIRECTION OF FLOATING (Position of port, switch rail, stroke adjustment function)

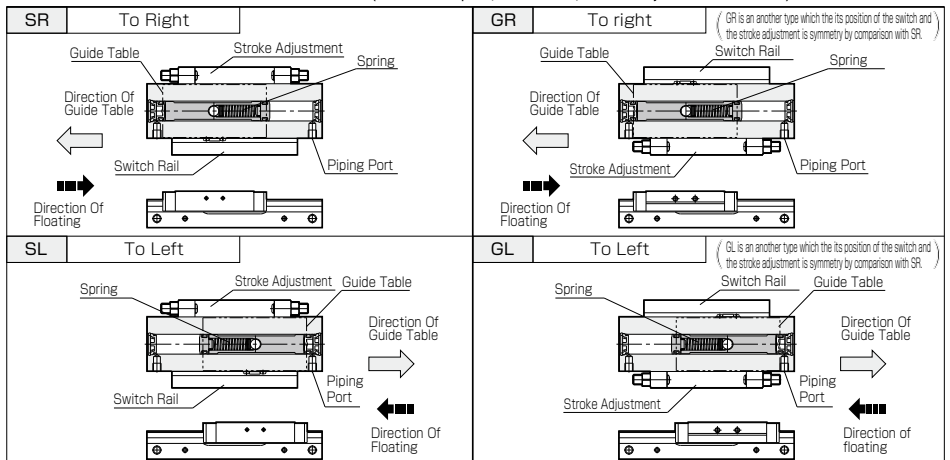

This figure is a sectional drawing from the product just above. It can not be change direction of floating.

# OPTIONAL PARTS CODES



Name

<b>PARTS CODE</b> Note
<b>PARTS CODE</b> Note
Content



Switch Fixture

<b>BE(PPT)</b> Screw, nut



Reed Switch(2 Wires, with Indicator Light)  
Straight Outlet Cable Angle Outlet Cable

<b>RB1(PPT)</b> Cable Length:1m	<b>RC1(PPT)</b> Cable Length:1m
<b>RB1LA(PPT)</b> Cable Length:3m	<b>RC1LA(PPT)</b> Cable Length:3m
	
with fixture	with fixture



Reed Switch(2 Wires, without Indicator Light)  
Straight Outlet Cable Angle Outlet Cable

<b>RB2(PPT)</b> Cable Length:1m	<b>RC2(PPT)</b> Cable Length:1m
<b>RB2LA(PPT)</b> Cable Length:3m	<b>RC2LA(PPT)</b> Cable Length:3m
	
with fixture	with fixture

Solid State Switch(2 Wires, with Indicator Light)  
Straight Outlet Cable Angle Outlet Cable

<b>RB4(PPT)</b> Cable Length:1m	<b>RC4(PPT)</b> Cable Length:1m
<b>RB4LA(PPT)</b> Cable Length:3m	<b>RC4LA(PPT)</b> Cable Length:3m
	
with fixture	with fixture



Solid State Switch(3 Wires, with Indicator Light)  
Straight Outlet Cable Angle Outlet Cable

<b>RB5(PPT)</b> Cable Length:1m	<b>RC5(PPT)</b> Cable Length:1m
<b>RB5LA(PPT)</b> Cable Length:3m	<b>RC5LA(PPT)</b> Cable Length:3m
	
with fixture	with fixture

Switch Rail

<b>RJ(PPT(Bore size)-(Stroke))</b> Example : For PPT10 with 20stroke. RJ(PPT10-20) Note : RJ can be selected for PPT8,10,12,16

with fixing bolts

Magnet

<b>RK(PPT8)</b> For PPT8 Before mounting, apply anaerobic adhesive to the screws.	<b>RK(PPT)</b> For PPT10, 12, 16 Before mounting, apply anaerobic adhesive to the screws.
	
with M1.6 mounting screws	with M2 mounting screws

O-ring for Base Mounted

<b>HS(PPT)</b> For PPT8,10,12,16  CSφ1, IDφ10

10 O-rings

Repair Parts Kit

<b>HP(PPTF□)</b> Fill in □ as bore size
For details  Page132

Spring for Floating

<b>B(PPTF[A]-[B])</b> [A] Bore size [B] Stroke Ex. For PPTF-SL8-10 B(PPTF8-10)

Plug

<b>BS-M5</b> with gasket	<b>BR-M5</b> Coat BR-M5 with seal tapes or sealing liquid when using it.
	

Note : Is not included spring for floating

Note : Available for SR, SL, GR and GL.

With Floating PICO TABLE

# PARTS CODES

## Adjuster Bolt

Object	PARTS CODE
For PPT8 -10	AJ(M5-16)
For PPT8 -20	
For PPT10-10	
For PPT10-20	AJ(M5-22)
For PPT12-15	AJ(M6-18)
For PPT12-25	AJ(M6-22)
For PPT16-20	AJ(M8-25)
For PPT16-30	



with nut

## Stroke Adjuster(Both Sides Metal Stopper) For PPT8,10,12

QR(PPT(Bore size)-(Stroke))
Example : For PPT10 with 20 stroke. QR(PPT10-20) Before mounting, apply an anaerobic adhesive to the screw.



with fixing bolts

## Stroke Adjustment(Metal stopper) For PPT16

QR(PPT16)
Before mounting, apply an anaerobic adhesive to the bolts.



with fixing bolts

## Adjuster Bolt With Rubber

Object	PARTS CODE
For PPT8 -10	AR(M5-16)
For PPT8 -20	
For PPT10-10	
For PPT10-20	AR(M5-22)
For PPT12-15	AR(M6-18)
For PPT12-25	AR(M6-22)
For PPT16-20	AR(M8-25)
For PPT16-30	



with nut

## Stroke Adjustment(Both sides Rubber Stopper) For PPT8,10,12

QT(PPT(Bore size)-(Stroke))
Example : For PPT10 with 20 stroke. QR(PPT10-20) Before mounting, apply an anaerobic adhesive to the screw.



with fixing bolts

## Stroke Adjustment(Rubber Stopper) For PPT16

QT(PPT16)
Before mounting, apply an anaerobic adhesive to the bolts.



with fixing bolts

## Lock Nut For Adjustment Bolt

Object	PARTS CODE
M5(M5×0.8)	NTA(M5)
M6(M6×1)	NTA(M6)
M8(M8×1.25)	NTA(M8)



Common use for Adjustment Bolt and Rubber Adjustment Bolt.

## Stroke Adjustment(Shock Absorber) For PPTF10,12

QK(PPTF-[B][C])
[B]:Floating Direction [C]:Bore size Example: For PPTF-SR10-20, QK(PPTF-SR10) Before mounting, apply anaerobic adhesive to the screw.



Only SR and SL  
with fixing bolts

## Stroke Adjustment(Shock Absorber) For PPTF8,16

QK(PPTF-[B][C])
[B]:Floating Direction [C]:Bore size Example: For PPTF-SR16-30, QK(PPTF-SR16) Before mounting, apply anaerobic adhesive to the screw.



Only SR and SL  
with fixing bolts

## Lock Nut For Shock Absorber

Object	PARTS CODE
ABK8(M8×0.75)	NTS(M8)
ABK10(M10×1)	NTS(M10)



- Shock Absorber is converted to new type.
- It can be replaced to conventional shock absorber.
- Length of ABK10 is 8mm longer than ABS10.

## Shock Absorber

ABK8	ABK10
For PPT 8 For PPT10 For PPT12	

M8×0.75



with nut

M10×1



with nut

# MASS OF PPTF

Unit:g

Model	Basic Mass	Additional Mass for Switch and Switch Rail (PPTFS)	Additional Mass for the Stroke Adjustment		
			Both Sides Metal Stopper(QR)	Both Sides Rubber Stopper(QT)	Single Side Shock Absorber(QK)
PPTF8 -10	100	10	35	35	50
PPTF8 -20	160	15	45	45	50
PPTF10-10	135	15	40	40	60
PPTF10-20	210	20	60	60	60
PPTF12-15	215	15	70	70	80
PPTF12-25	320	25	90	90	80
PPTF16-20	445	15	100	100	85
PPTF16-30	610	20	100	100	85

Note: The same mass for SR, SL, GR, GL, TP and PP

# MASS OF SWITCH

Unit:g

Switch Type	Mass
RB1, RC1, RB2, RC2	15
RB4, RC4, RB5, RC5	
RB1LA, RC1LA, RB2LA, RC2LA	35
RB4LA, RC4LA, RB5LA, RC5LA	

# METHOD TO CALCULATE THE MASS

Ex. PPTFS-SR10-20-PPQK-RC52LA

Basic Mass..... 210g  
 Magnet, Switch Rail..... 20g  
 Shock Absorber..... 60g  
 Switch..... 35×2=70g  
 210+20+60+70=360g

# THEORETICAL THRUST

Unit:N

Bore Size (mm)	Operating Pressure MPa					
	0.2	0.3	0.4	0.5	0.6	0.7
φ8	5.9	11	16	21	26	31
φ10	11	19	26	34	42	50
φ12	18	29	40	52	63	74
φ16	32	52	72	92	110	130

Spring force at floating is excluded.

With Floating

PICO TABLE

PICO TABLE



## THE TYPE OF LINEAR BEARING

Model	Stroke	Type
PPTF8	10	THK RSR9C1
	20	THK RSR9C1 long
PPTF10	10	IKO LWL12
	20	IKO LWL12 long
PPTF12	15	IKO LWL15
	25	IKO LWL15 long
PPTF16	20	IKO LWL20
	30	IKO LWL20 long

Pre-load: Zero or slightly pre-loaded

## STROKE ADJUSTMENT RANGE

Model	Stroke	Metal Stopper	Rubber Stopper	Shock Absorber
		QR	QT	QK
PPTF8	10	-5mm on both sides	-5mm on both sides	-10mm on single side
	20	-5mm on both sides	-5mm on both sides	-8mm on single side
PPTF10	10	-6mm on both sides	-6mm on both sides	-10mm on single side
	20	-7mm on both sides	-7mm on both sides	-18mm on single side
PPTF12	15	-5mm on both sides	-5mm on both sides	-12mm on single side
	25	-5mm on both sides	-5mm on both sides	-17mm on single side
PPTF16	20	-10mm on both sides	-10mm on both sides	-20mm on single side
	30	-10mm on both sides	-10mm on both sides	-30mm on single side

## OPTION COMBINATION TABLE

Model	Direction of Floating	With Magnet, Switch Rail	Piping			Stroke Adjustment		
			Side	Base	Metal Stopper	Rubber Stopper	Shock Absorber	
			S	TP	PP	QR	QT	QK
PPTF8	SR, SL	○	○	○	○	○	○	
	GR, GL	○	○	○	○	○	×	
PPTF10	SR, SL	○	○	○	○	○	○	
	GR, GL	○	○	○	○	○	×	
PPTF12	SR, SL	○	○	○	○	○	○	
	GR, GL	○	○	○	○	○	×	
PPTF16	SR, SL	○	○	○	○	○	○	
	(GR, GL)	—	—	—	—	—	—	

GL(GR) can be converted from SL(SR) of PPTF16 by changing plug positions.  
For details  page 134

# STRUCTURE AND PRINCIPAL COMPONENTS

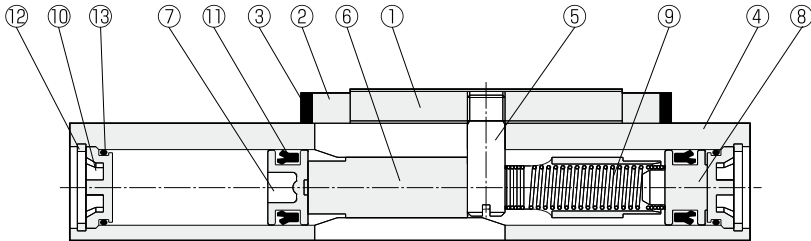

## COMPONENTS

No.	Name	Material	Remarks	No.	Name	Material	Remarks
1	Guide Table	Stainless Steel	Heat Treatment	6	Center Piston	Synthetic Resin	
2	Side Plate	Synthetic Resin		7	Piston A	Synthetic Resin	
3	Dust Seal	NBR		8	Piston B	Synthetic Resin	
4	Body	Stainless Steel	Heat Treatment	9	Spring	Stainless Steel	
5	Center Pin	Stainless Steel		10	End Cover	Synthetic Resin	

## REPAIR PARTS

No.	Name	Material	Qty	Remarks	No.	Name	Material	Qty	Remarks
11	Piston Seal	NBR	2		13	O-ring	NBR	2	
12	Circlip	Carbon Steel	2	Nickel Plating					

With Floating

PICO TABLE

PICO TABLE

## With Stroke Adjustment Mechanism

PPTF8, 10, 12 With Metal Stopper

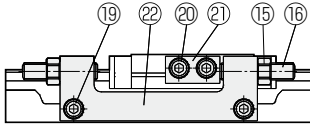

PPTF8, 10, 12 With Rubber Stopper

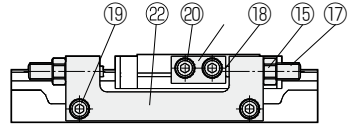

PPTF16 With Metal Stopper

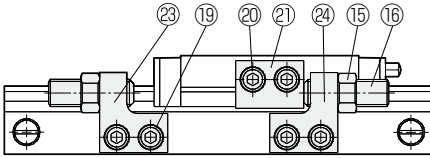

PPTF16 With Rubber Stopper

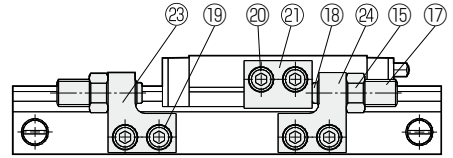

PPTF10, 12 With Shock Absorber

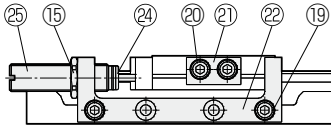

PPTF8, 16 With Shock Absorber

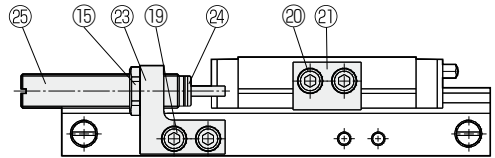

No.	Name	Material	Remarks	No.	Name	Material	Remarks
15	Nut	Carbon Steel	Nickel Plating	21	Stopper Receiver	Tool Steel (Heat Treatment)	Electroless Nickel Plating
16	Adjuster Bolt	Steel(Heat Treatment)	Nickel Plating	22	Adjuster Block	Carbon Steel	Electroless Nickel Plating
17	Adjustment Bolt (for Rubber)	Stainless Steel		23	Adjuster Block	Carbon Steel	Electroless Nickel Plating
18	Cushioning Rubber	Urethane Rubber		24	Metal Stopper	Carbon steel	Heat Treatment(Nitriding)
19	Bolt	Structural Alloy Steel	Nickel Plating	25	Shock Absorber	Copper Alloy Carbon Steel(For PPT8,10,12) Carbon Steel(PPT16 only)	Electroless Nickel Plating
20	Bolt	Structural Alloy Steel	Nickel Plating				

## MODIFICATION OF PORT POSITION (only PPTF16)

### ■ Side Ported(TP)

Only PPTF16 has ports on both sides of the body.

When TP is delivered, the plugs(BS-M5) are attached to the ports on the datum plane side of the body. A gasket is provided on the washer face of BS-M5. So, BS-M5 can be easily mounted and removed with a wrench or a screwdriver. You can freely change the position in accordance to your application such as symmetrical mounting.

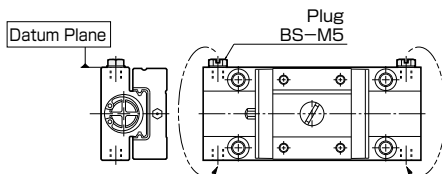

### ■ Base Mounted(PP)

In case of PP of PPTF16, the plug BS-M5 with gasket on the washer face is fitted on both sides of the body. This type can be used as TP by sealing air with O-ring between the body bottom and the base and removing the plug.

It is recommended to purchase the product of PP specification, if TP or PP will not be decided for application.

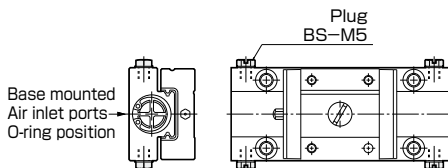

### ■ To Avoid Extrusion of the Plug Head from Body

Plug BR-M5(hexagon socket set screw) is recommended. (Both TP and PP)  
In this case, it is necessary to apply seal tape or sealing agent on the thread portion.

## CAUTIONS IN DESIGN OR USE FOR FLOATING MECHANISM

### ⚠ Warning

#### Spring Force

Do not use floating mechanism for the purpose as single return or fall prevention of the actuator itself.

#### Actual Stroke

When floating, work is stopped at the position where only floating stroke moved backward from stroke of actuator.

Please pay attention when stroke is chosen.

#### Absorption of Collision Energy

The floating mechanism can not absorb the collision energy. For absorption of that energy, consider other mechanism such as air cushion or shock absorber.

#### Vertical Installment

If the actuator will be installed vertically, the direction of floating should not be downward. In this case the floating can not be effective.

#### Position of Guide Table when Air Pressure is Absent Inside the Actuator

When air pressure is exhausted, the guide table may locate to either stroke end by spring for floating inside the actuator. At the time, the spring extends freely. (for reference to mechanics for floating)  
Besides, the spring force becomes weaker than theoretical spring force as set at this condition.

#### Exchange of Spring

An original spring inside the actuator can be exchanged to another spring arranged by a customer.

Specification and Design for spring for floating

☞ page 135.

Over extension or over compression may cause malfunction for floating.

## SPRING FOR FLOATING

For designed value of spring for PPTF, refer to the list below.

For designing the spring by yourself, refer to the below JIS.

JIS B 2702 Hot Formed Coil Spring  
 JIS B 2704 Design Criteria of Extension Coil Spring and Compression  
 JIS B 2707 Cold Formed Compression Coil Spring

Model	Floating Stroke (mm)	The Minimum Internal Diameter of Spring (mm)	The Maximum External Diameter of Spring (mm)	The Length of Spring as Set (mm)	The Length of Spring At Stroke End (mm)	The Length of Spring as Free (mm)
PPTF8-10	3	3.9	4.9	10.4	7.4	23
PPTF8-20	5	3.9	4.9	20.4	15.4	43
PPTF10-10	3	4.8	5.9	9.4	6.4	22
PPTF10-20	5	4.8	5.9	19.4	14.4	42
PPTF12-15	5	5.7	6.9	14.4	9.4	32
PPTF12-25	5	5.7	6.9	24.4	19.4	52
PPTF16-20	5	6.6	8.2	20.1	15.1	43
PPTF16-30	5	6.6	8.2	30.1	25.1	63

### Explanation

Item	Explanation	Caution
Floating Stroke	The value is set for every code.	Not arranged. Keep value in the list.
The Minimum Internal Diameter of Spring	Internal dimensions of spring.	Keep value or more in the list, otherwise, the spring can not be installed with the piston.
The Maximum External Diameter of Spring	External dimensions of spring.	Keep value or less in the list, otherwise, the spring can not be installed with the piston.
The Length of Spring as Set	The length of spring when the floating starts to work.	Not arranged. Keep value in the list.
The Length of Spring at Stroke End	The length of spring when the floating works at the end of its stroke.	Not arranged. Keep value in the list.
The Length of Spring as Free	The length of spring when it is free(not compressed).	Keep value or more in the list.
The Number of End Turn	The shape of spring at the end.	Wind the spring for two times or more at the either seat.

Note: Consider the resistance of bearing for calculating spring force

### Exchange of Spring

Procedure	Comment
<ol style="list-style-type: none"> <li>1. Remove the stopper ring</li> <li>2. Remove the end cover</li> <li>3. Remove the piston from body</li> </ol>	The piston and end cover may be sent out by the compressed spring while disassembling.
<ol style="list-style-type: none"> <li>4. Put the another spring into body</li> <li>5. Put the piston into body</li> <li>6. Put the end cover</li> <li>7. Put the stopper ring to fix these parts</li> </ol>	<p>Check the direction of spring for assembling.</p> <p>Confirm that spring, piston and end cover are fixed surely.</p>

# DIMENSIONS(mm) PPTF-SR(SL)8-10

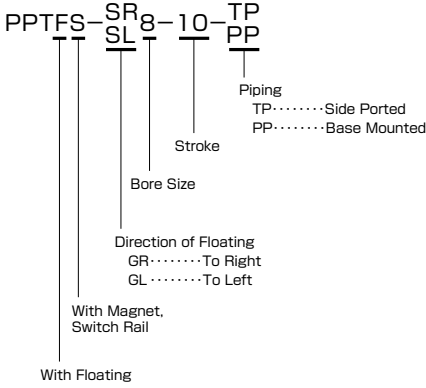

Position of Switch  116 Page

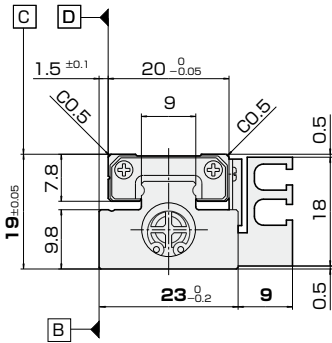
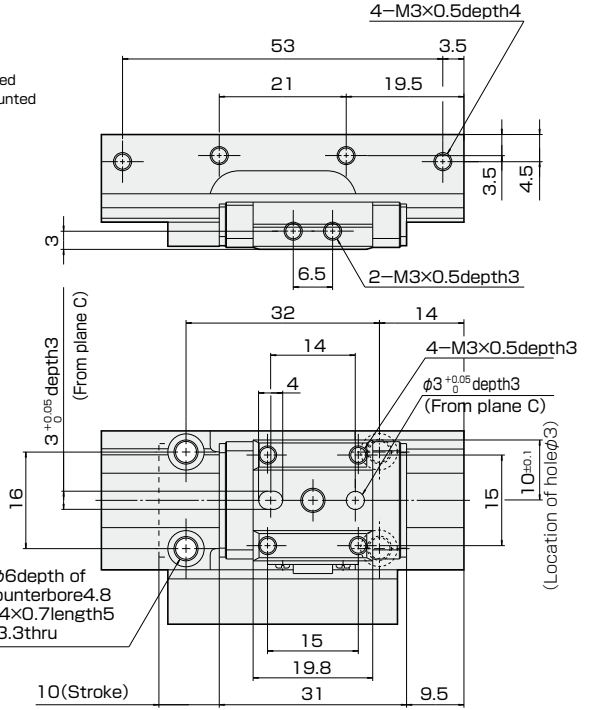

C D - Datum plane

2-φ9.5(O-ring inside diameter)  
(Only PP)

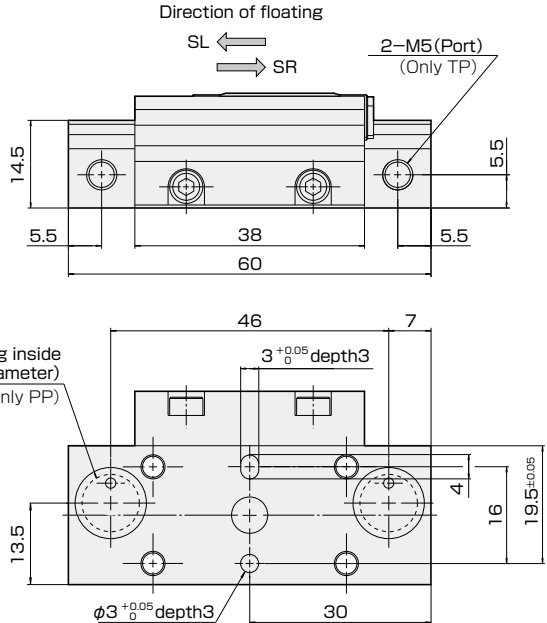

PPTF-SR(SL)8-10

With Floating

T-T

PICO TABLE

### Without Magnet, Switch Rail

PPTF-SR-TP  
SL-8-10-PP

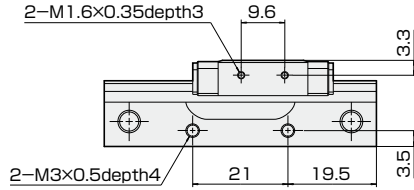
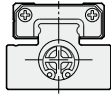

### With Metal Stopper, with Rubber Stopper

PPTF(S)-SR-TP QR  
SL-8-10-PP QT

QR: Metal Stopper  
QT: Rubber Stopper  
Stroke Adjustment range:  
Both Sides 5mm each

Width across flats socket 2.5

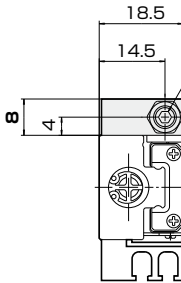

Width across flats 7

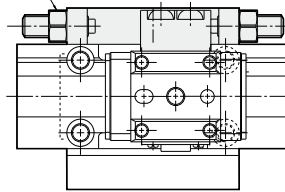
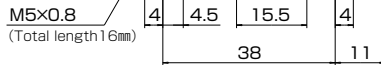

### With Shock Absorber

PPTF(S)-SR-TP QK  
SL-8-10-PP

Shock Absorber  
Stroke Adjustment Range:  
Single Side 10mm

SL(SR) has a shock absorber and an adjust block at either single side only. Page 129,133

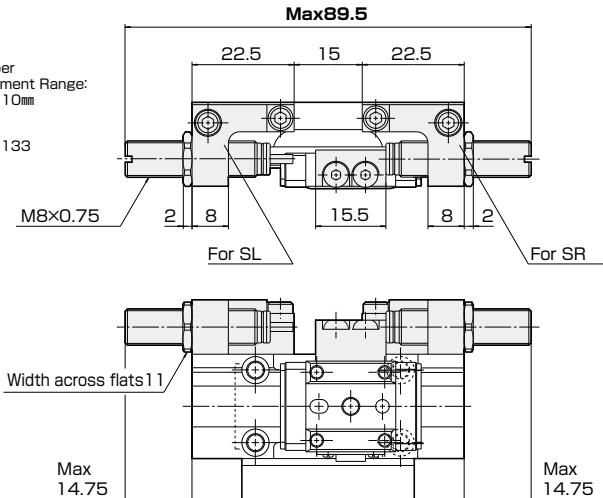
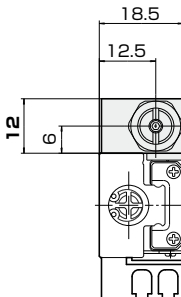

PPTF-SR(SL)8-10

With Floating

PICO TABLE

PICO TABLE

# DIMENSIONS(mm) PPTF-GR(GL)8-10

PPTFS-GR8-10-TP  
GL-PP

Piping  
TP.....Side Ported  
PP.....Base Mounted

Stroke

Bore Size

Direction of Floating  
GR.....To Right  
GL.....To Left

With Magnet,  
Switch Rail

With Floating

Position of Switch  116 Page

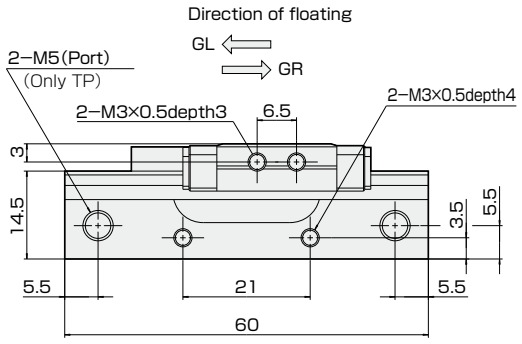
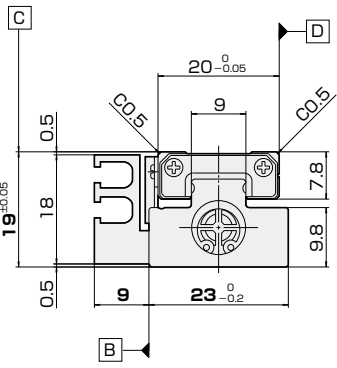
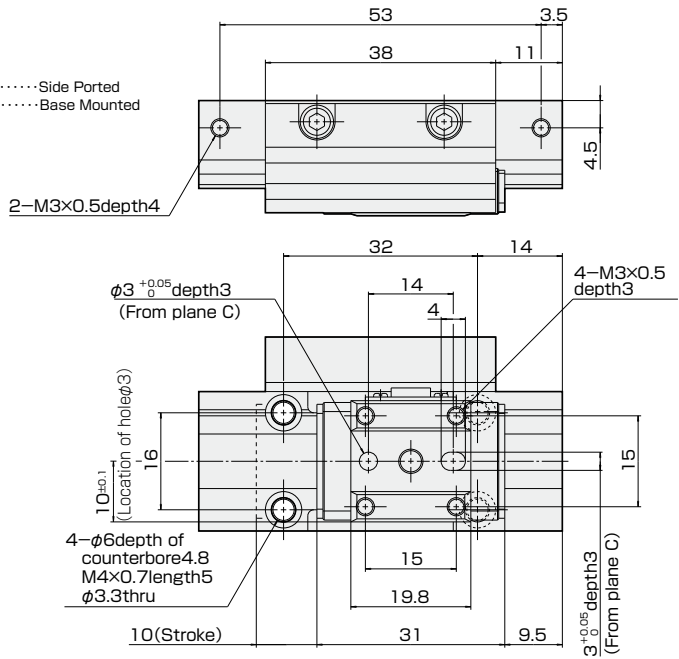

**B** **D** - Datum plane

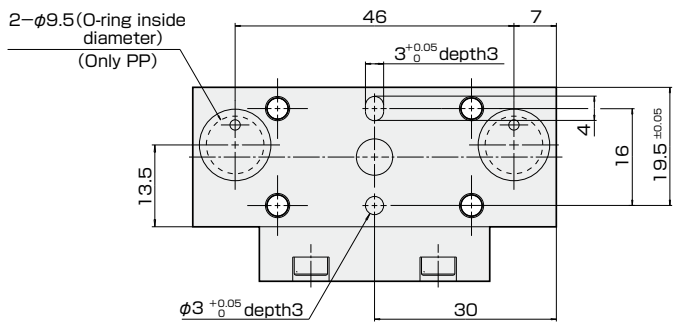

PPTF-GR(GL)8-10 With Floating PICO TABLE



### Without Magnet, Switch Rail

PPTF-GR-10-TP  
GL-PP

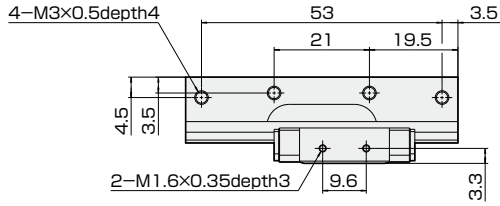
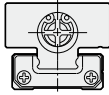

### With Metal Stopper, with Rubber Stopper

PPTF(S)-GR-10-TP QR  
GL-PP QT

QR: Metal Stopper  
QT: Rubber Stopper  
Stroke Adjustment Range:  
Both Sides 5mm each

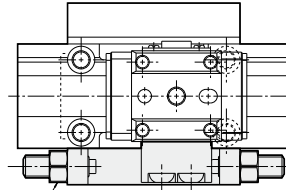

Width across flats 7

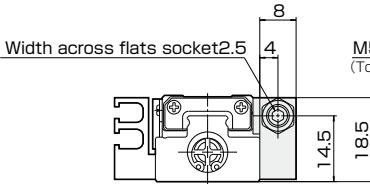

M5×0.8  
(Total length 16mm)

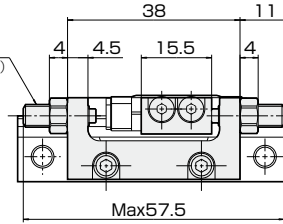

### With Shock Absorber

The shock absorber (QK) is NOT available for GR, GL.  
In this case, select SR, SL.

# DIMENSIONS(mm) PPTF-SR(SL)8-20

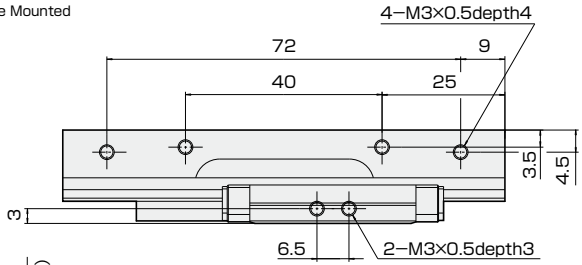
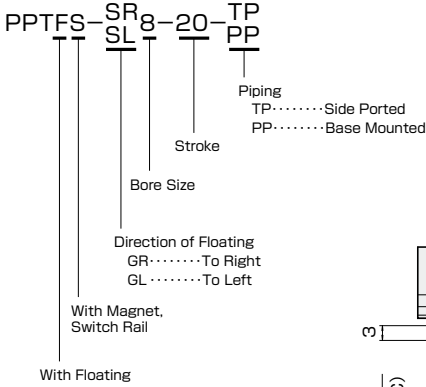

Position of Switch 116 Page

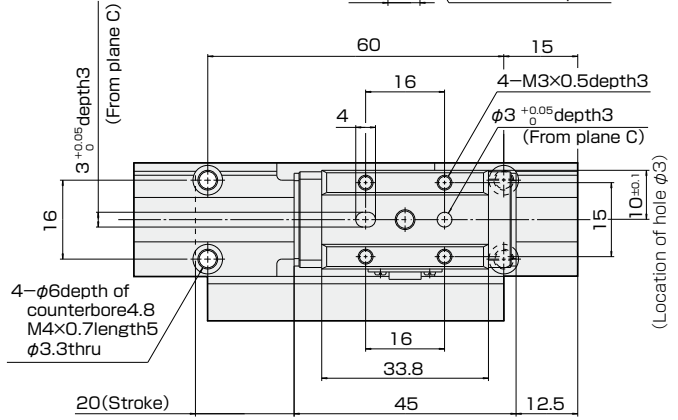

PPTF-SR(SL)8-20

With Floating

T-T-T

PICO TABLE

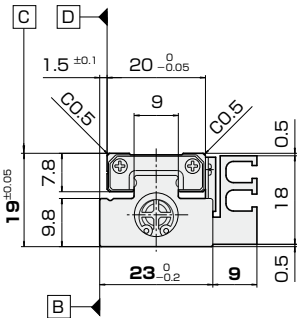

B D - Datum plane

2-phi 9.5(O-ring inside diameter)  
(Only PP)

Direction of floating

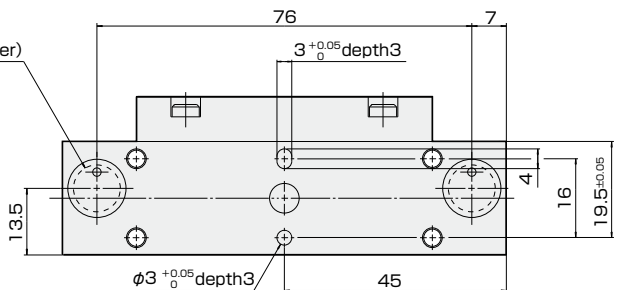
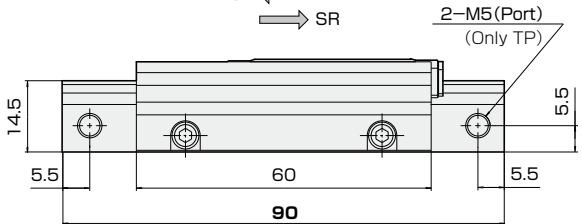
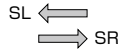

### Without Magnet, Switch Rail

PPTF-SR-TP  
SL-8-20-PP

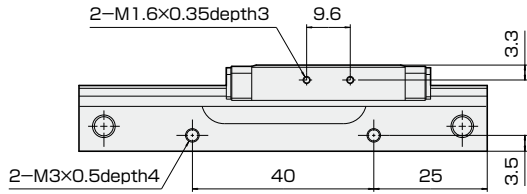
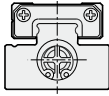

### With Metal Stopper, with Rubber Stopper

PPTF(S)-SR-TP QR  
SL-8-20-PP QT

QR: Metal Stopper  
QT: Rubber Stopper  
Stroke Adjustment Range:  
Both Sides 5mm each

Width across flats socket 2.5

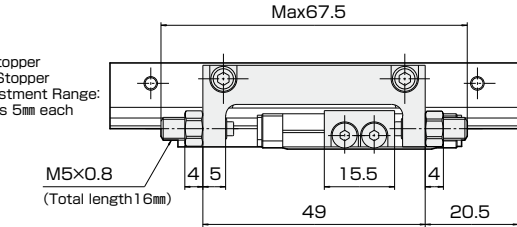
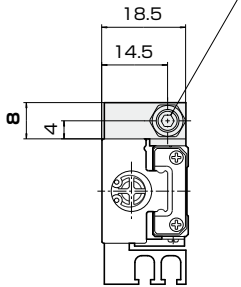

Width across flats 7

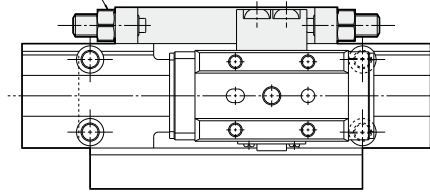

### With Shock Absorber

PPTF(S)-SR-TP QK  
SL-8-20-PP

Shock Absorber  
Stroke Adjustment Range:  
Single Side 8mm

SL(SR) has a shock absorber and an adjust block at either single side only. 129, 133 Page

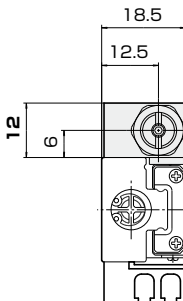

Width across flats 11 For SL

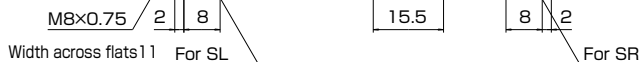

Max 4.75

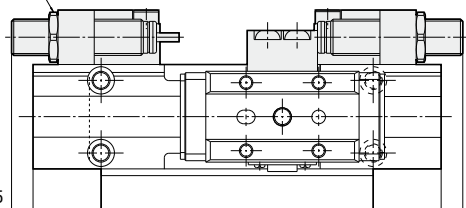

Max 4.75

PPTF-SR(SL) 8-20

With Floating

PICO TABLE

# DIMENSIONS(mm) PPTF-GR(GL)8-20

PPTFS-GR8-20-TP  
GL PP

Piping  
TP.....Side Ported  
PP.....Base Mounted

Stroke

Bore Size

Direction of Floating  
GR.....To Right  
GL.....To Left

With Magnet,  
Switch Rail

With Floating

Position of Switch  116 Page

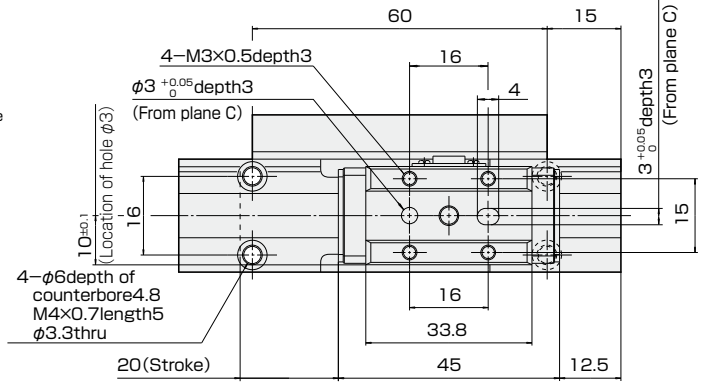
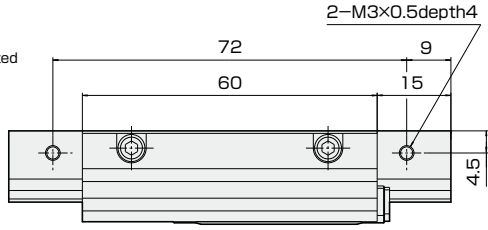

PPTF-GR(GL)8-20

With Floating

TUTU

PICO TABLE

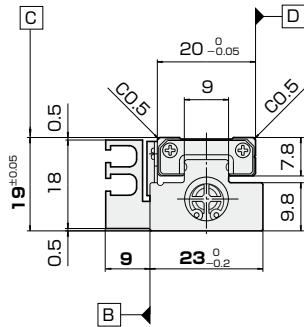

B D - Datum plane

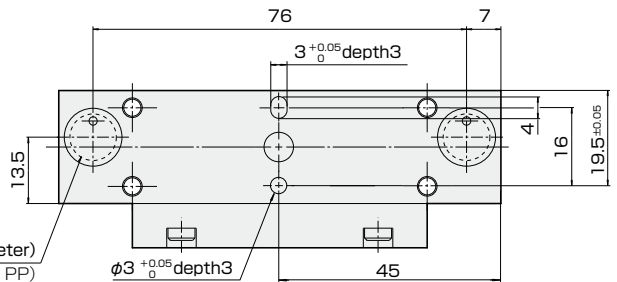
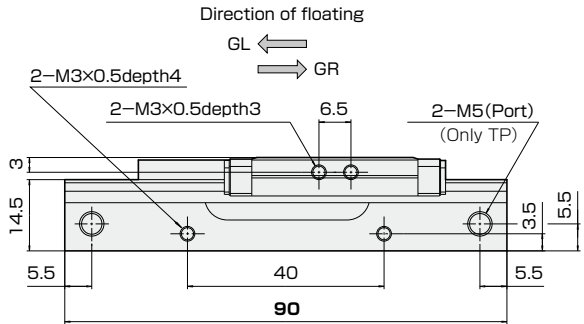

### Without Magnet, Switch Rail

PPTF-GR8-20-TP  
GL-PP

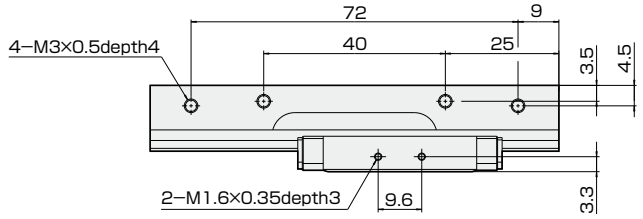
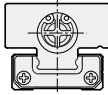

### With Metal Stopper, with Rubber Stopper

PPTF(S)-GR8-20-TP QR  
GL-PP QT

QR: Metal Stopper  
QT: Rubber Stopper  
Stroke Adjustment Range:  
Both Sides 5mm each

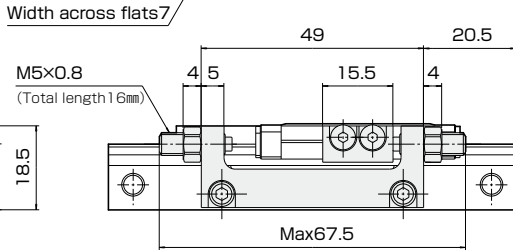
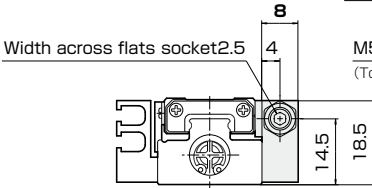
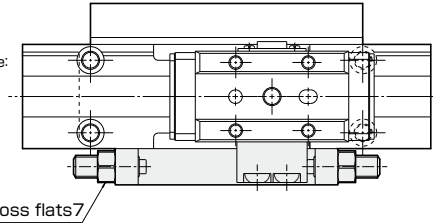

### With Shock Absorber

The shock absorber (QK) is NOT available for GR, GL.  
In this case, select SR, SL.

PPTF-GR(GL)8-20

With Floating

PICO TABLE

PICO TABLE

# 外形寸法図 PPTF-SR(SL)10-10

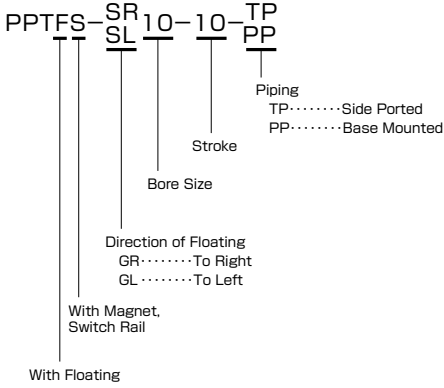

Position of Switch  116 Page

PPTF-SR(SL)10-10

With Floating

T-T

PICO TABLE

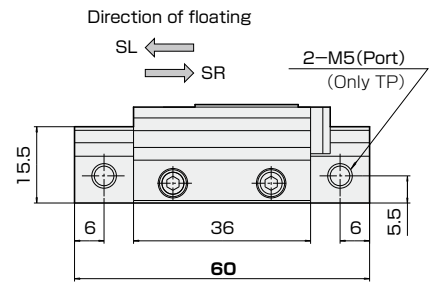
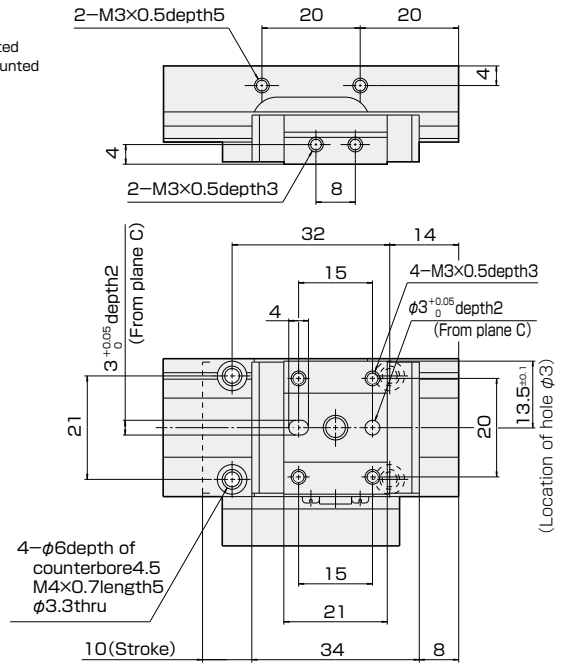
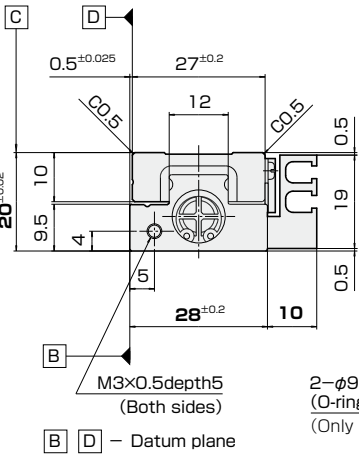

2-φ9.5 (O-ring inside diameter) (Only PP)

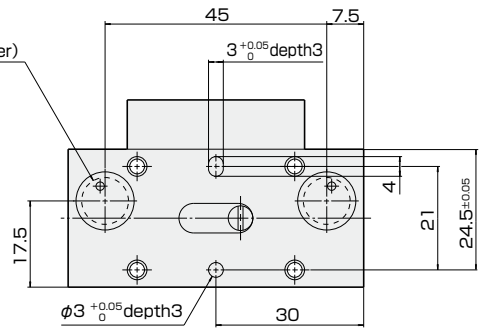

### Without Magnet, Switch Rail

PPTF-SR  
SL 10-10-TP  
PP

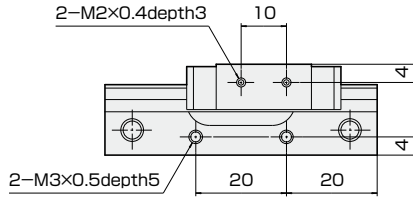
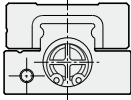

### With Metal Stopper, with Rubber Stopper

PPTF(S)-SR  
SL 10-10-TP QR  
PP QT

QR: Metal Stopper  
QT: Rubber Stopper  
Stroke Adjustment Range:  
Both Sides 6mm each

Width across flats socket 2.5

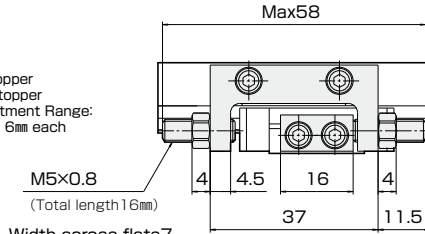
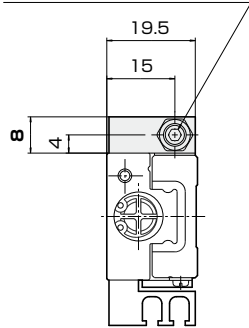

M5x0.8  
(Total length 16mm)

Width across flats 7

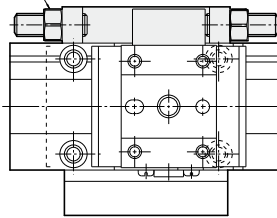

### With Shock Absorber

PPTF(S)-SR  
SL 10-10-TP QK  
PP

Shock Absorber  
Stroke Adjustment Range:  
Single Side 10mm

SL(SR) has a shock absorber for single side only.  
☞ Page 129, 133

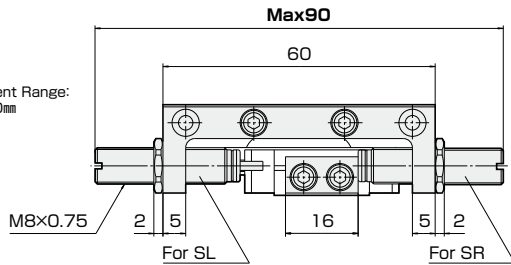
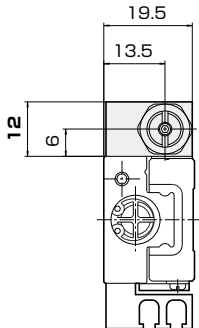

M8x0.75

For SL

For SR

Width across flats 11

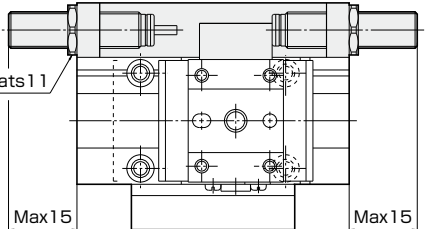

Max 15

Max 15

# DIMENSIONS(mm) PPTF-GR(GL)10-10

PPTFS-GR10-10-TP  
GL PP

Piping  
TP.....Side Ported  
PP.....Base Mounted

Stroke

Bore Size

Direction of Floating  
GR.....To Right  
GL.....To Left

With Magnet,  
Switch Rail

With Floating

Position of Switch  116 Page

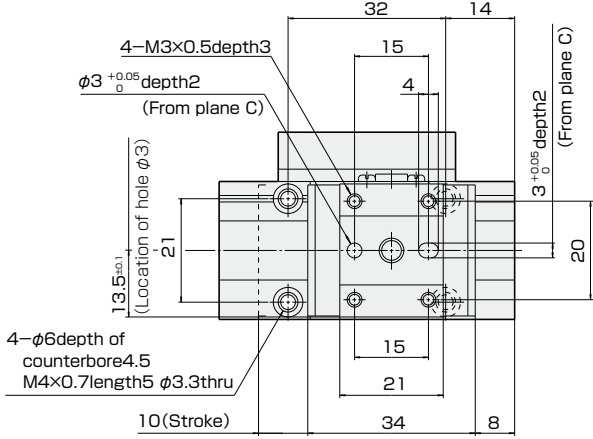
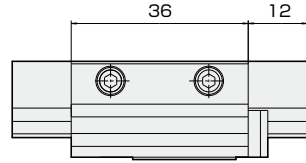

Direction of floating

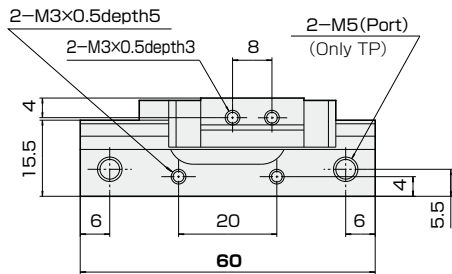
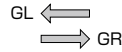

PPTF-GR(GL)10-10

With Floating

TT-TTT

PICO TABLE

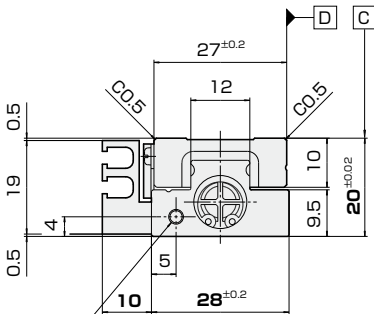

M3×0.5depth5  
(Both sides)

2-φ9.5(O-ring inside diameter)  
(Only PP)

B D - Datum plane

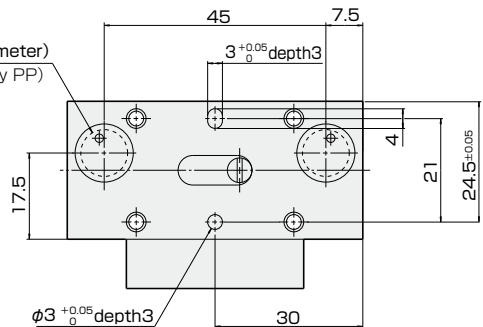



### Without Magnet, Switch Rail

PPTF-<sup>GR</sup><sub>GL</sub>10-10-<sup>TP</sup><sub>PP</sub>

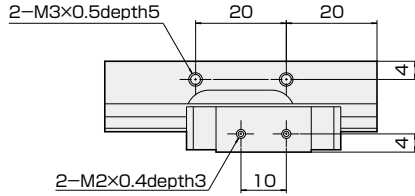
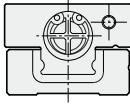

### With Metal Stopper, with Rubber Stopper

PPTF(S)-<sup>GR</sup><sub>GL</sub>10-10-<sup>TP</sup><sub>PP</sub> <sup>QR</sup><sub>QT</sub>

QR: Metal Stopper  
QT: Rubber Stopper  
Stroke Adjustment Range:  
Both Sides 6mm each

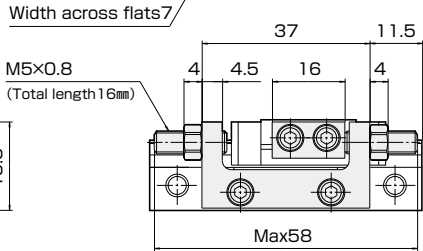
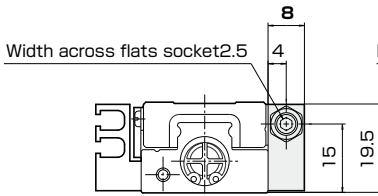
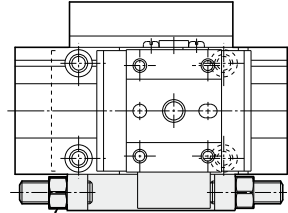

### With Shock Absorber

The shock absorber (QK) is NOT available for GR, GL.  
In this case, select SR, SL.

PPTF-GR(GL)10-10

With Floating

Π-ΠΠ

PICO TABLE

# DIMENSIONS(mm) PPTF-SR(SL) 10-20

PPTFS-SR 10-20-TP  
 SL PP

Piping  
 TP.....Side Ported  
 PP.....Base Mounted

Stroke

Bore Size

Direction of Floating  
 GR.....To Right  
 GL.....To Left

With Magnet,  
 Switch Rail

With Floating

Position of Switch  116 Page

PPTF-SR(SL) 10-20

With Floating

PICO TABLE

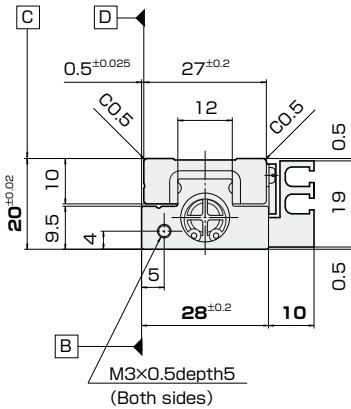

**B** **D** - Datum plane

2- $\phi 9.5$ (O-ring inside diameter)  
 (Only PP)

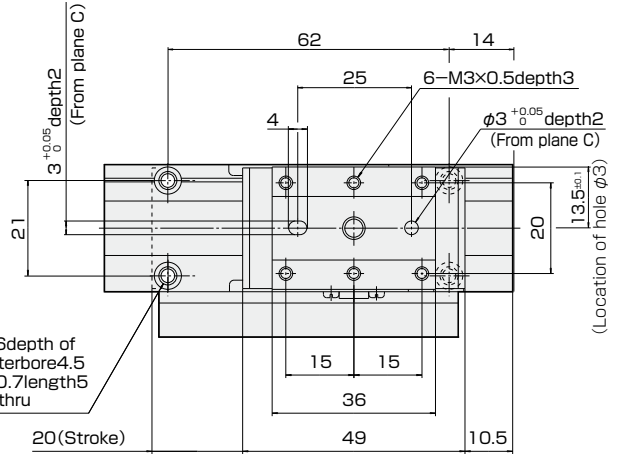
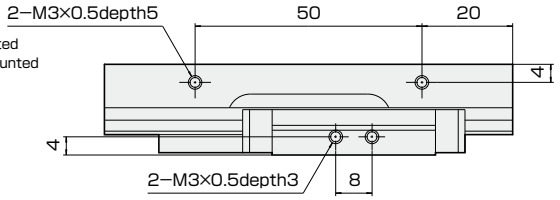

Direction of floating

SL ←  
 → SR

2-M5(Port)  
 (Only TP)

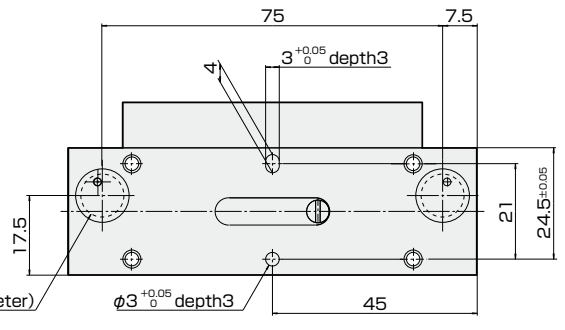
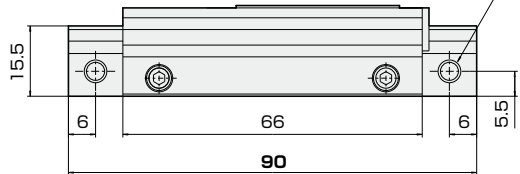

### Without Magnet, Switch Rail

PPTF-SR<sub>10-20</sub>-TP  
SL-PP

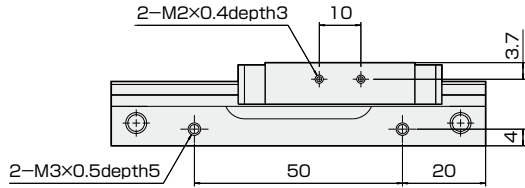
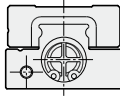

### With Metal Stopper, with Rubber Stopper

PPTF(S)-SR<sub>10-20</sub>-TP QR  
SL-PP QT

QR: Metal Stopper  
QT: Rubber Stopper  
Stroke Adjustment Range:  
Both Sides 7mm each

Width across flats socket 2.5

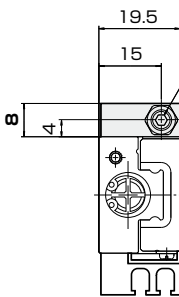

M5x0.8  
(Total length 22mm)

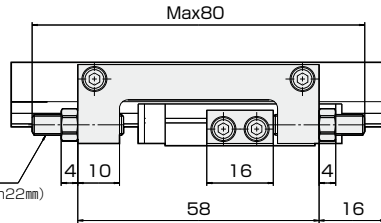

Width across flats 7

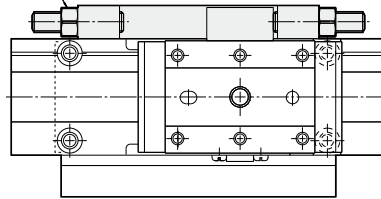

### With Shock Absorber

PPTF(S)-SR<sub>10-20</sub>-TP QK  
SL-PP

Shock absorber  
Stroke adjustment range:  
Single side 18mm

SL(SR) has a shock absorber for single side only.  
Page 129, 133

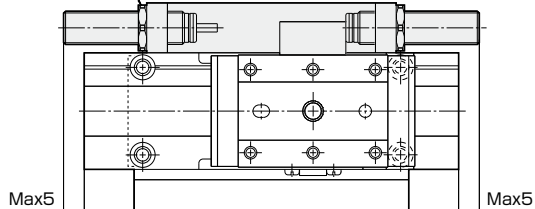
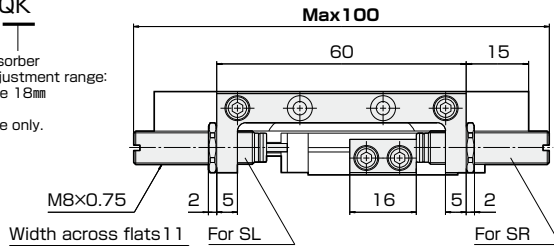
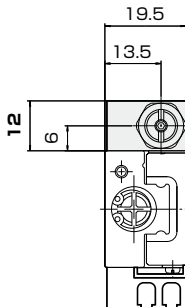

PPTF-SR(SL)10-20

With Floating

PICO TABLE

PICO TABLE

# DIMENSIONS(mm) PPTF-GR(GL)10-20

PPTFS-GR10-20-TP  
GL PP

Piping  
TP.....Side Ported  
PP.....Base Mounted

Stroke

Bore Size

Direction of Floating  
GR.....To Right  
GL.....To Left

With Magnet,  
Switch Rail

With Floating

Position of Switch  116 Page

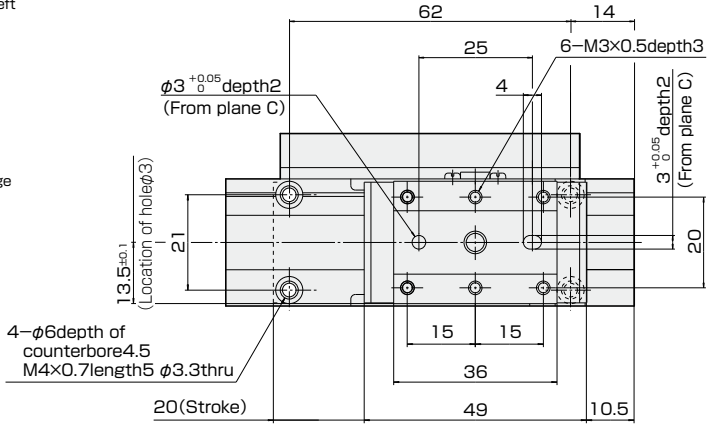
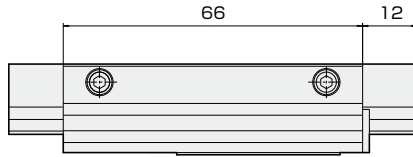

PPTF-GR(GL)10-20

With Floating

TUTU

PICO TABLE

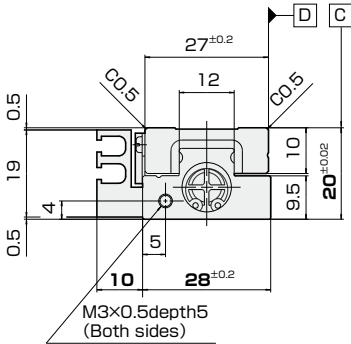

**B** **D** - Datum plane

Direction of floating

GL ←  
→ GR

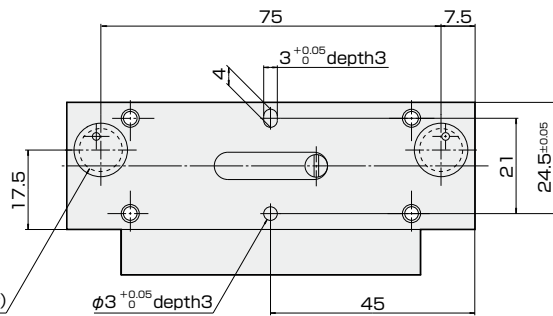
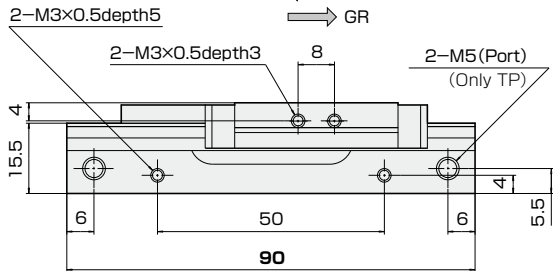

### Without Magnet, Switch Rail

PPTF-GR TP  
GL 10-20 PP

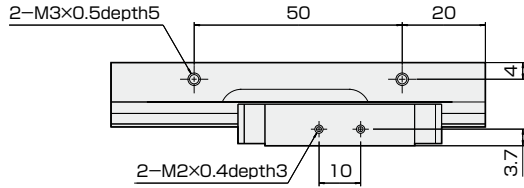
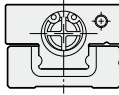

### With Metal Stopper, with Rubber Stopper

PPTF(S)-GR TP QR  
GL 10-20 PP QT

QR: Metal Stopper  
QT: Rubber Stopper  
Stroke Adjustment Range:  
Both Sides 7mm each

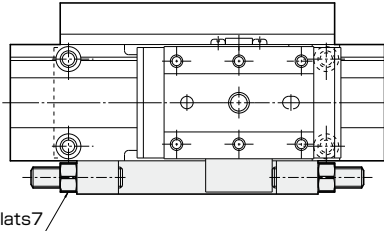

Width across flats 7

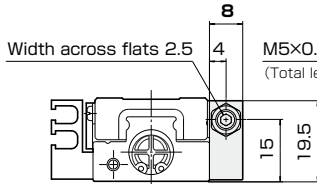

M5x0.8  
(Total length 22mm)

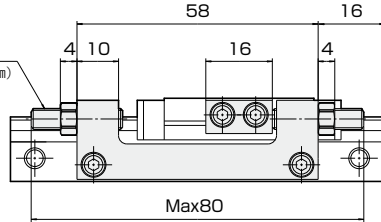

### With Shock Absorber

The shock absorber (QK) is NOT available for GR, GL.  
In this case, select SR, SL.

PPTF-GR(GL) 10-20

With Floating

PICO TABLE

PICO TABLE

# DIMENSIONS(mm) PPTF-SR(SL)12-15

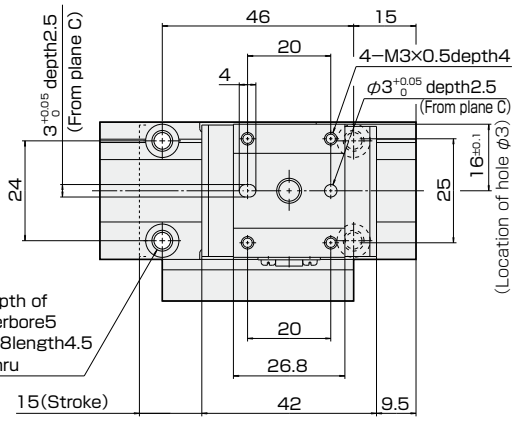
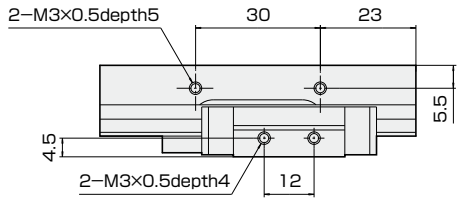
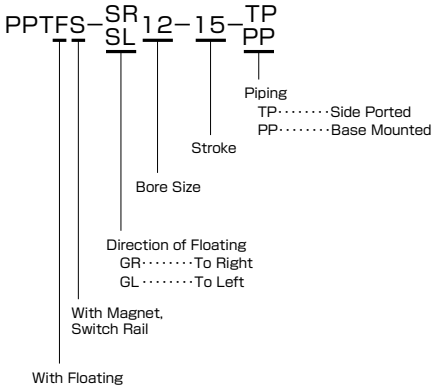

PPTF-SR(SL)12-15

With Floating

PICO TABLE

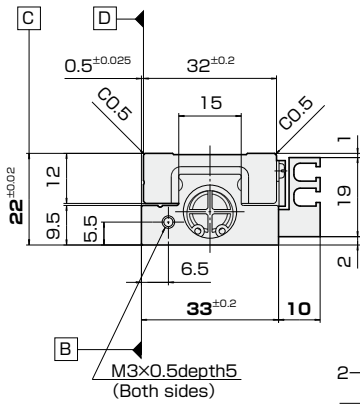

B D - Datum plane

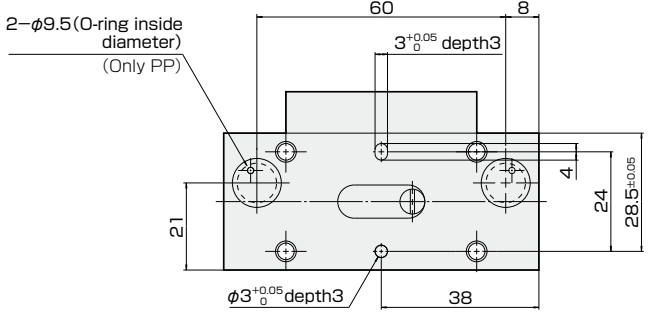
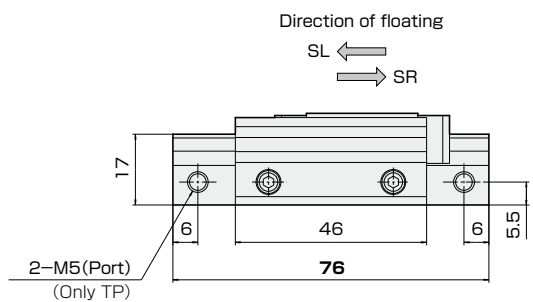

### Without Magnet, Switch Rail

PPTF-SR<sub>12-15</sub>-TP  
SL-PP

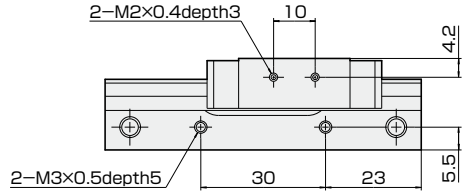
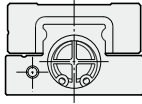

### With Metal Stopper, with Rubber Stopper

PPTF(S)-SR<sub>12-15</sub>-TP QR  
SL-PP QT

QR: Metal Stopper  
QT: Rubber Stopper  
Stroke Adjustment Range:  
Both Sides 5mm each

Width across flats socket3

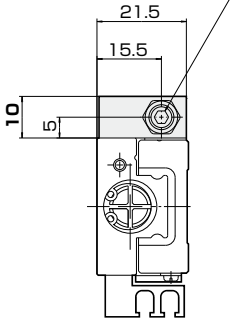

M6x1  
(Total length 18mm)

Width across flats 8

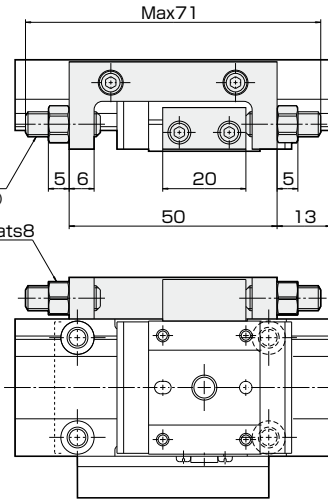

### With Shock Absorber

PPTF(S)-SR<sub>12-15</sub>-TP QK  
SL-PP

Shock Absorber  
Stroke Adjustment Range:  
Single Side 12mm

SL(SR) has a shock absorber for single side only.  
Page 129, 133

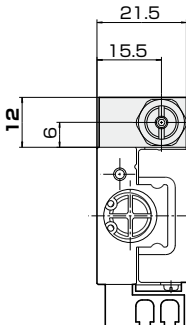

Width across flats 11

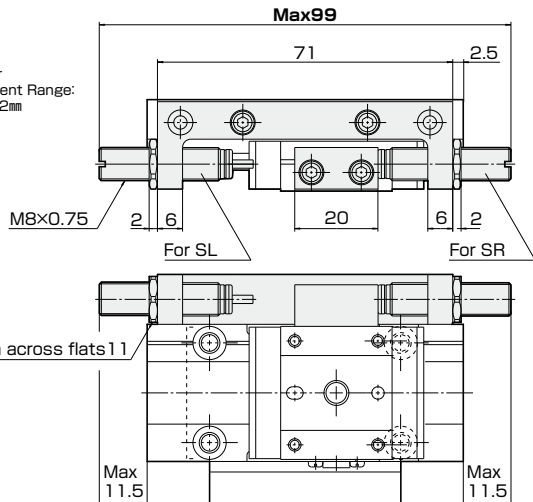

PPTF-SR(SL) 12-15

With Floating

PICO TABLE

PICO TABLE

# DIMENSIONS(mm) PPTF-GR(GL)12-15

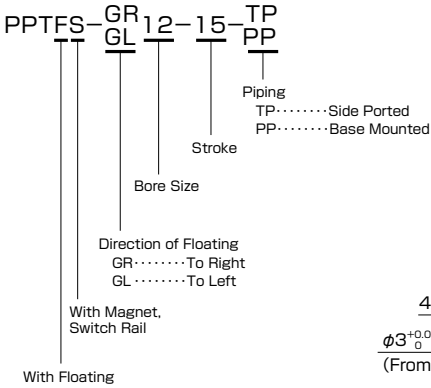

Position of Switch 116 Page

PPTF-GR(GL)12-15

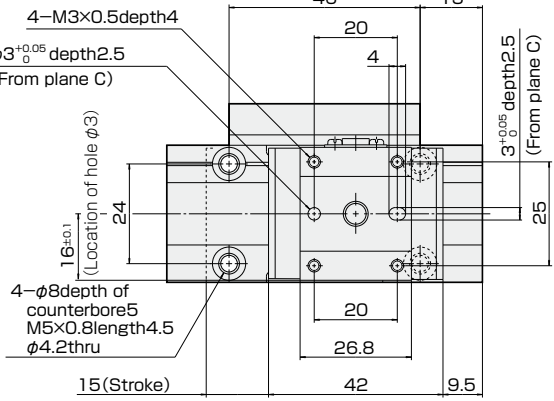
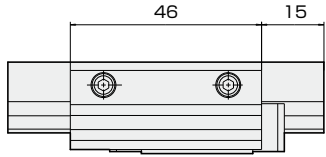

PICO TABLE T-1100 With Floating

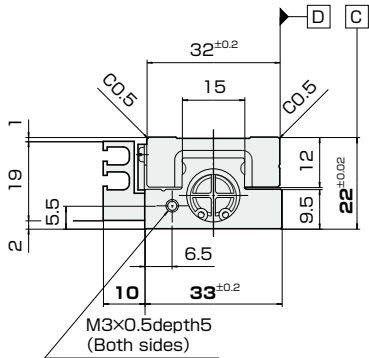

**B D** - Datum plane

Direction of floating

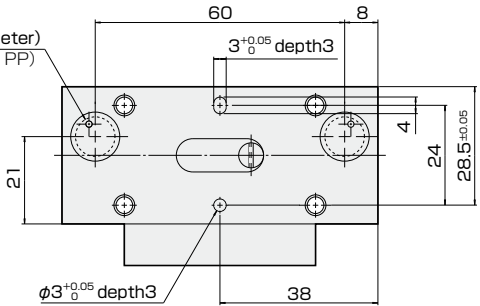
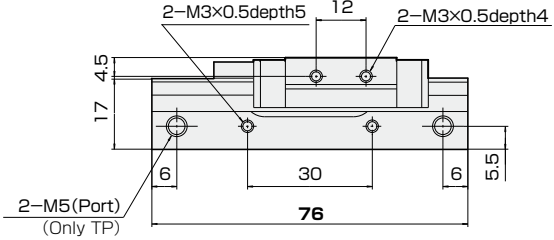
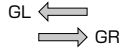



### Without Magnet, Switch Rail

PPTF-GR-TP  
GL-12-15-PP

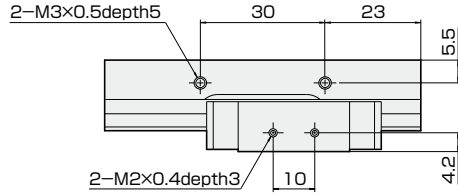
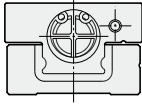

### With Metal Stopper, with Rubber Stopper

PPTF(S)-GR-TP QR  
GL-12-15-PP QT

QR: Metal Stopper  
QT: Rubber Stopper  
Stroke Adjustment Range:  
Both Sides 5mm each

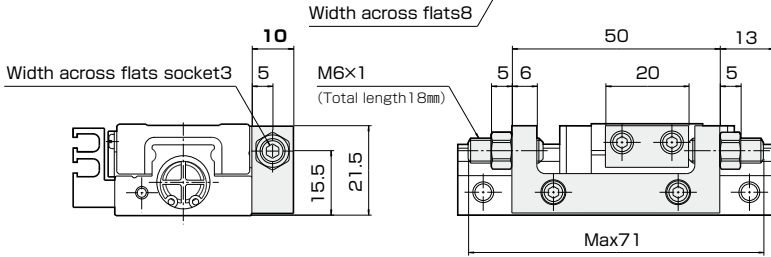
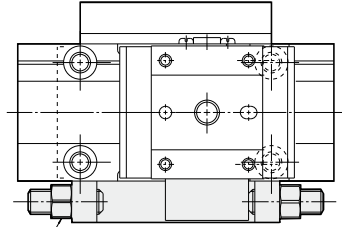

### With Shock Absorber

The shock absorber (QK) is NOT available for GR, GL.  
In this case, select SR, SL.

PPTF-GR(GL) 12-15

With Floating

PPTF

PICO TABLE

# DIMENSIONS(mm) PPTF-SR(SL) 12-25

PPTFS-SR 12-25-TP  
 SL PP

Piping  
 TP.....Side Ported  
 PP.....Base Mounted

Stroke

Bore Size

Direction of Floating  
 GR.....To Right  
 GL.....To Left

With Magnet,  
 Switch Rail

With Floating

Position of Switch  116 Page

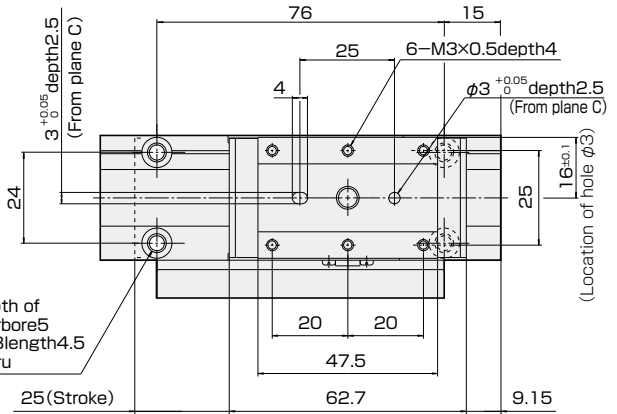
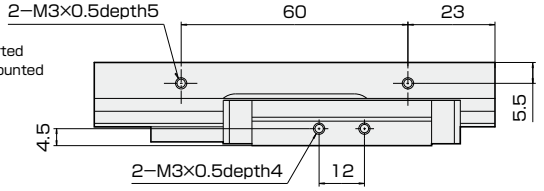

Direction of floating

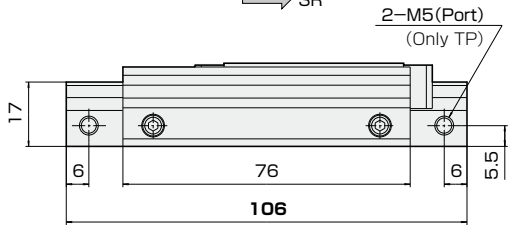
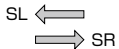

PPTF-SR(SL) 12-25

With Floating

TUTU

PICO TABLE

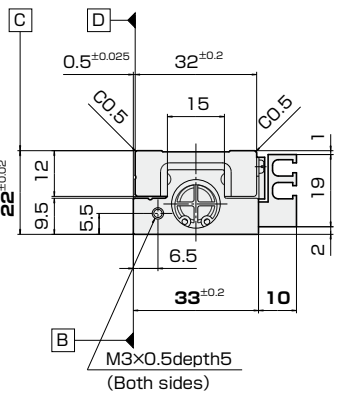

**B** **D** - Datum plane

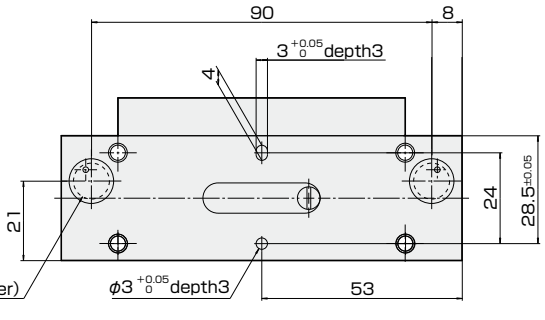

### Without Magnet, Switch Rail

PPTF-SR 12-25-TP  
SL PP

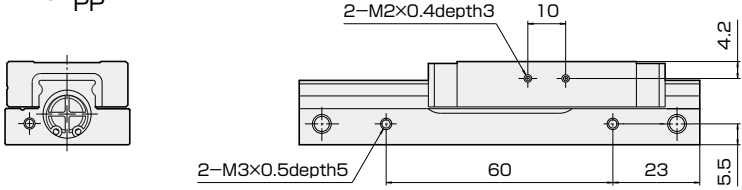

### With Metal Stopper, with Rubber Stopper

PPTF(S)-SR 12-25-TP QR  
SL PP QT

QR: Metal Stopper  
QT: Rubber Stopper  
Stroke Adjustment Range:  
Both Sides 5mm each

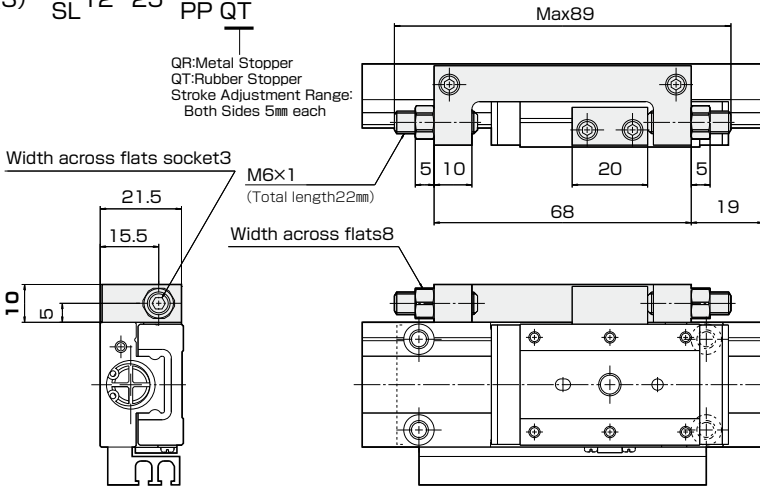

### With Shock Absorber

PPTF(S)-SR 12-25-TP QK  
SL PP

Shock Absorber  
Stroke Adjustment Range:  
Single Side 17mm

SL(SR) has a shock absorber for single side only.  
Page 129, 133

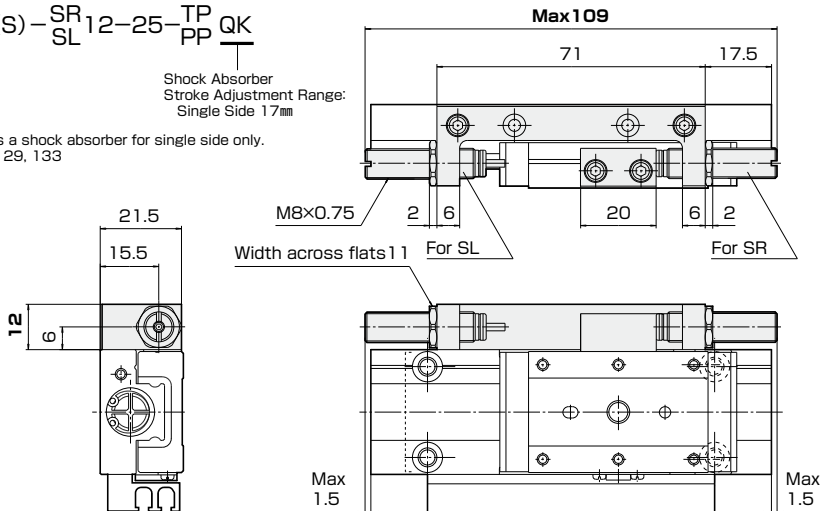

PPTF-SR(SL) 12-25

With Floating

PICO TABLE

PICO TABLE

# DIMENSIONS(mm) PPTF-GR(GL) 12-25

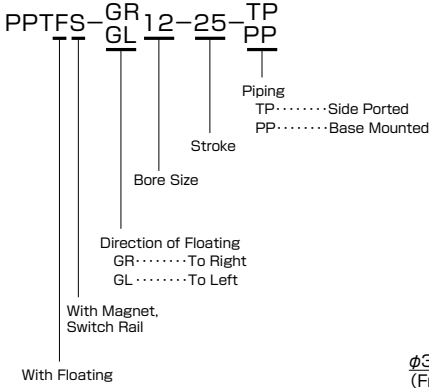

Position of Switch  116 Page

PPTF-GR(GL) 12-25

With Floating

T-T

PICO TABLE

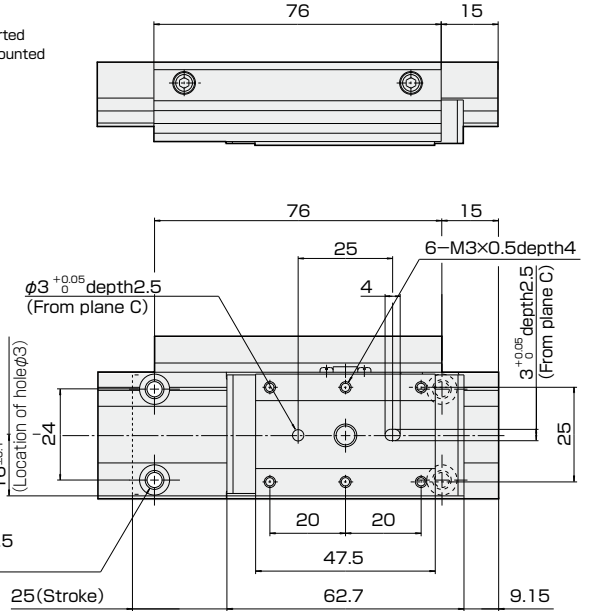

Direction of floating

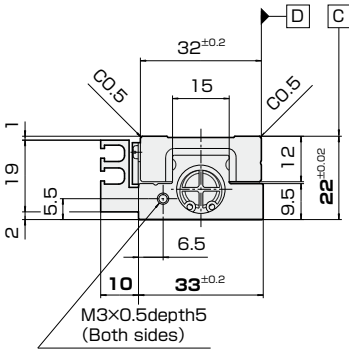
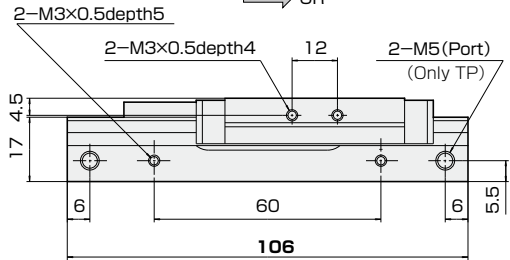
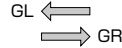

B D - Datum plane

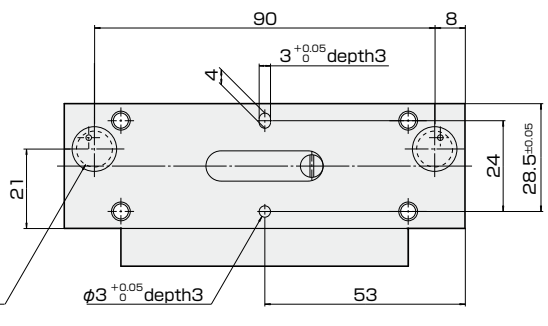

### Without Magnet, Switch Rail

PPTF-GR TP  
GL 12-25 PP

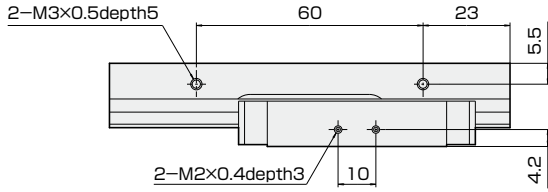
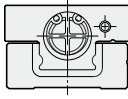

### With Metal Stopper, with Rubber Stopper

PPTF(S)-GR TP QR  
GL 12-25 PP QT

QR: Metal Stopper  
QT: Rubber Stopper  
Stroke Adjustment Range:  
Both Sides 5mm each

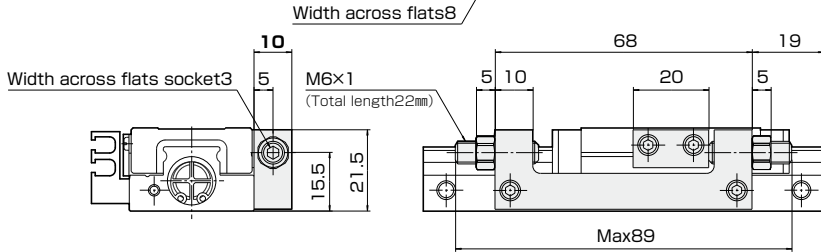
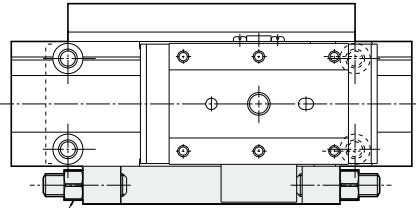

### With Shock Absorber

The shock absorber (QK) is NOT available for GR, GL.  
In this case, select SR, SL.

PPTF-GR(GL) 12-25

With Floating

PICO TABLE

PICO TABLE

# DIMENSIONS(mm) PPTF-SR(SL) 16-20

GL(GR) can be converted from SL(SR) by changing plug positions.

PPTFS-SR 16-20-TP  
SL PP

Piping  
TP.....Side Ported  
PP.....Base Mounted

Stroke  
Bore Size  
Direction of Floating  
GR.....To Right  
GL.....To Left

With Magnet,  
Switch Rail

With Floating

Position of Switch  116 Page

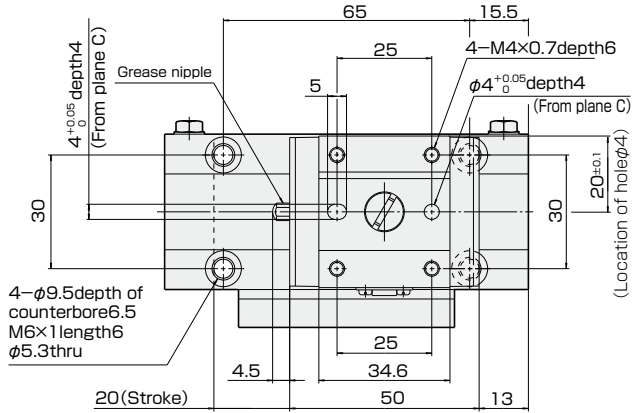
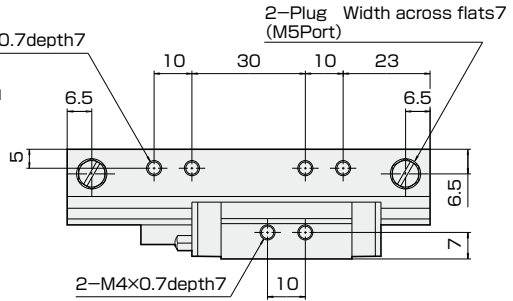

PPTF-SR(SL) 16-20

With Floating

TUTU

PICO TABLE

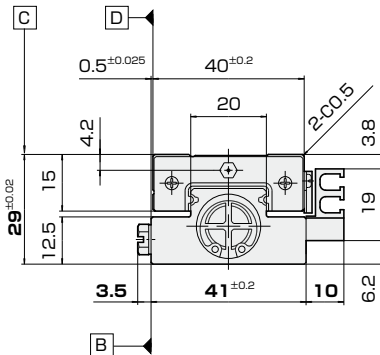

2-φ9.5(O-ring inside diameter) (Only PP)

Direction of floating

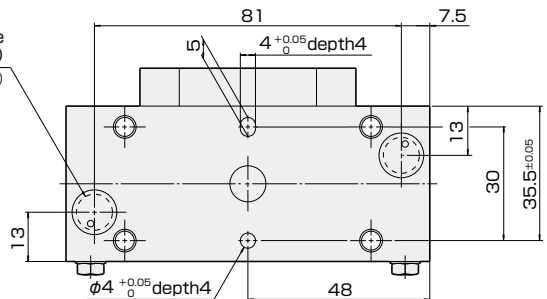
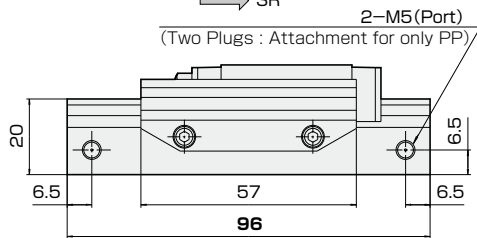

### Without Magnet, Switch Rail

PPTF-SR 16-20-TP  
SL-PP

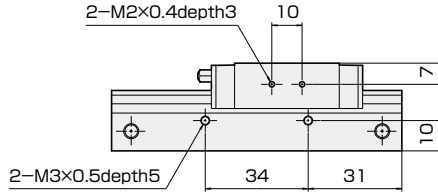
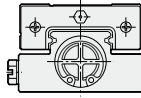

### With Metal Stopper, with Rubber Stopper

PPTF(S)-SR 16-20-TP QR  
SL-PP QT

QR: Metal Stopper  
QT: Rubber Stopper  
Stroke Adjustment Range:  
Both Sides 10mm each

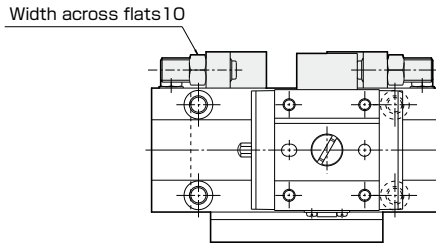
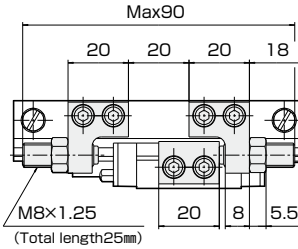
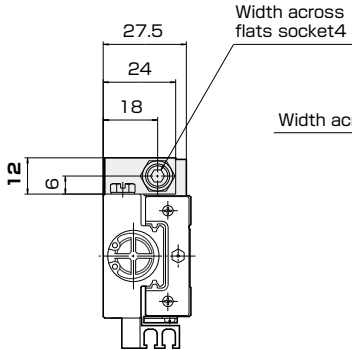

### With Shock Absorber

PPTF(S)-SR 16-20-TP QK  
SL-PP

Shock absorber  
Stroke adjustment range:  
Single side 20mm

SL(SR) has a shock absorber for single side only.  
Page 129, 133

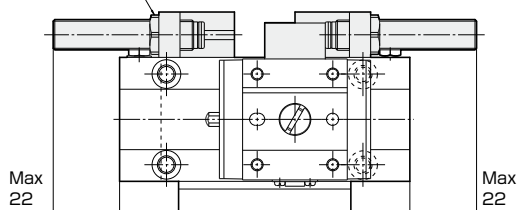
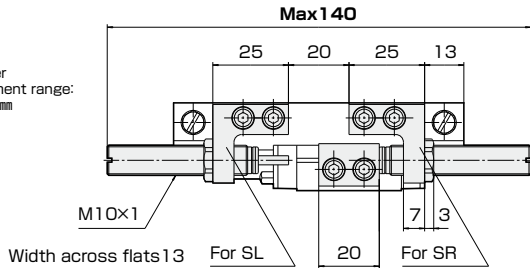
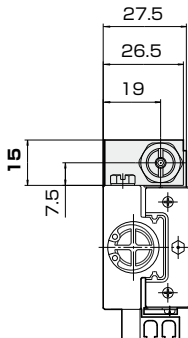

PPTF-SR(SL) 16-20

With Floating

PICO TABLE

PICO TABLE

# DIMENSIONS(mm) PPTF-SR(SL) 16-30

GL(GR) can be converted from SL(SR) by changing plug positions.

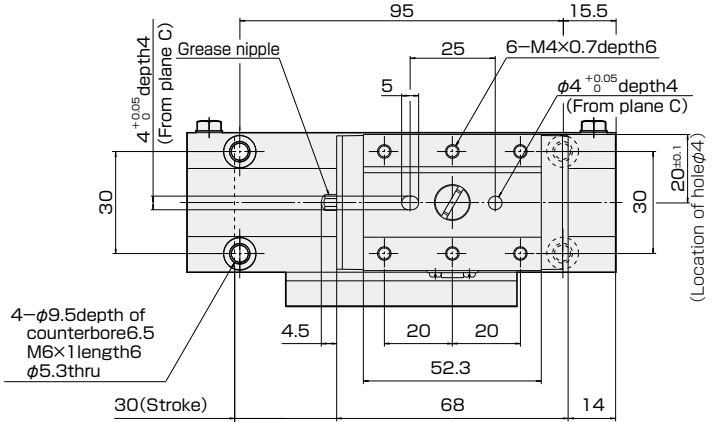
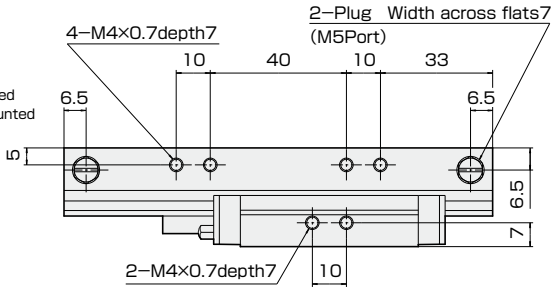
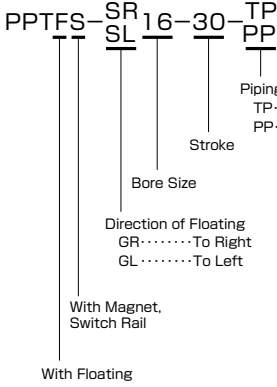

4-φ9.5 depth of counterbore 6.5  
M6x1 length 6  
φ5.3 thru

Position of Switch 116 Page

PPTF-SR(SL) 16-30

With Floating

TUTU

PICO TABLE

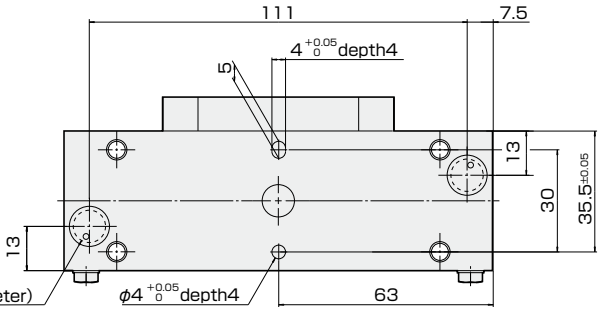
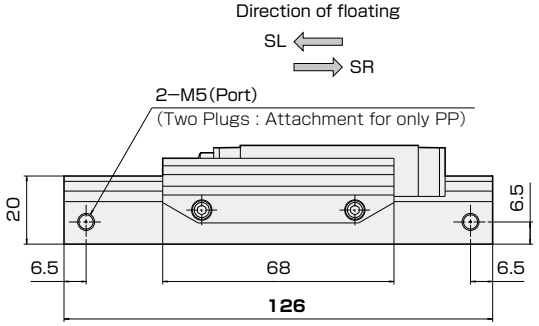
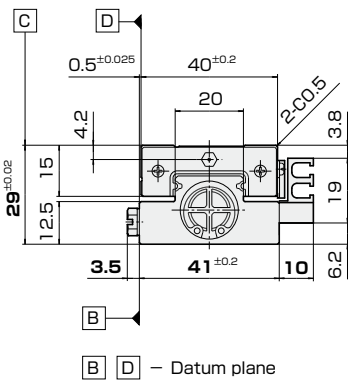



### Without Magnet, Switch Rail

PPTF-SR 16-30-TP  
SL-PP

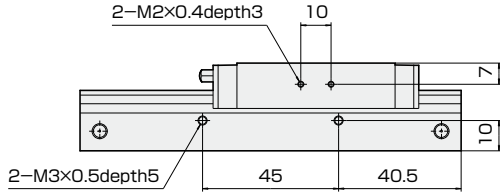
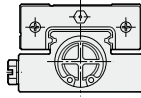

### With Metal Stopper, with Rubber Stopper

PPTF(S)-SR 16-30-TP QR  
SL-PP QT

QR: Metal Stopper  
QT: Rubber Stopper  
Stroke Adjustment Range:  
Both Sides 10mm each

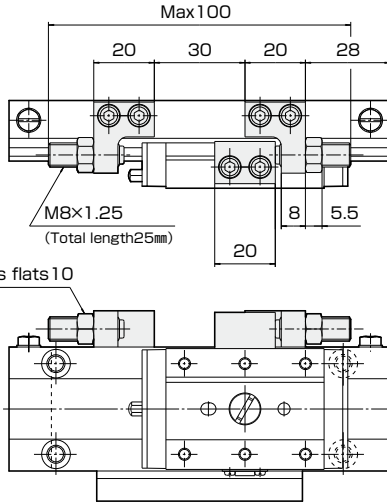
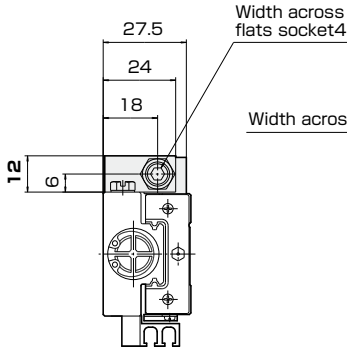

### With Shock Absorber

PPTF(S)-SR 16-30-TP QK  
SL-PP

Shock Absorber  
Stroke Adjustment Range:  
Single Side 30mm

SL(SR) has a shock absorber for single side only.  
Page 129, 133

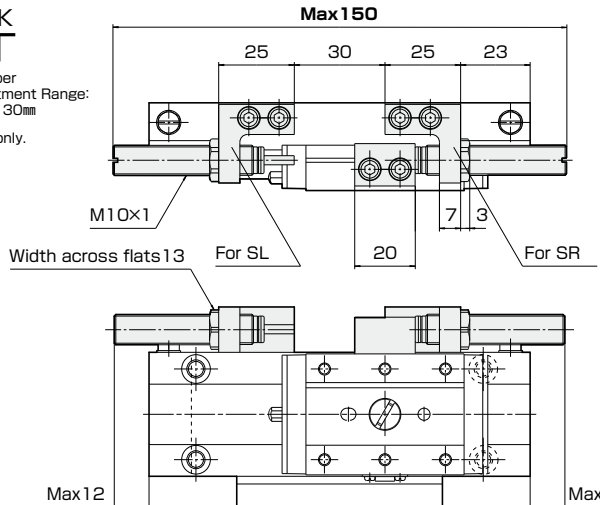
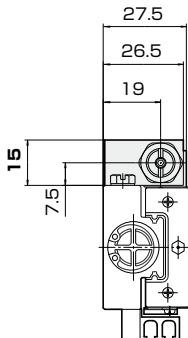

PPTF-SR(SL) 16-30

With Floating

PICO TABLE

PICO TABLE

# ■ MEMO ■

# ■ MEMO ■

# ■ MEMO ■

# ■ MEMO ■

# ■ MEMO ■